



User's manual



Revision History

Changes to the original manual are listed below:

Version	Date	Description of Version
1.0	October 21, 2009	Initial release
1.1	February 21, 2011	Added Power save mode and examples for trigger command
1.2	June 22, 2011	Added description in Edge Trigger Command

Important Notice

No warranty of any kind is made in regard to this material, including, but not limited to, implied warranties of merchantability or fitness for a particular purpose. We are not liable for any errors contained herein or incidental or consequential damages in connection with furnishing, performance or use of this material.

No part of this document may be reproduced, transmitted, stored in a retrieval system, transcribed, or translated into any language or computer language in any form or by any means electronic, mechanical, magnetic, optical, chemical, manual or otherwise, without express written consent and authorization.

We reserve the right to make changes in product design without reservation and without notification. The material in this guide is for information only and is subject to change without notice.

All trademarks mentioned herein, registered or otherwise, are the properties of their various respective owners.

Copyright © 2011. All rights reserved.

For CE-Countries

This scanner is in conformity with CE standards. Please note that an approved, CE-marked power supply unit should be used in order to maintain CE conformance.

Guidance for Printing

1. This manual is in A5 size. Please double check your printer setting before printing it out.
2. When printing barcodes for programming, the use of a high-resolution laser scanner is strongly suggested for the best scan result.

Table of Contents

Instruction	1
Outline	1
Mounting	2
Connection	4
Technical Specification	6
Dimension	7
Maintaining the Scanner	8
Blink Mode	8
Programming Guide	9
Parameter setting	13
Interface Setting	18
The Symbologies Setting	24

Instruction

With an easy-to-integrate design and an outstanding scanning performance, this middle-range CCD scan module is especially made for embedded scanning solution. Its powerful 2,500 pixel CCD enables 150 scans per second with a minimum resolution of 5mil for fast scans.

The scan module offers multiple interfaces including keyboard, RS-232C, and HID USB. Besides, it has three mounting holes on the back of the case reserved for quick and easy installation into your equipment. When working in field, its two-color LED in the front gives immediate scanning response and the programmable tone and beep time are to meet users' need and enhance productivity.

The module has a newly designed CCD scan engine with light beam bright and clear as laser beam that gives user best visual indication and its powerful high resolution CCD acts in remarkable performance.

Outline



Mounting

The scanner is designed to be easily embed into any space limited devices, and it has 3 screwed mounting holes reserved at the bottom.

- Screw description: M2 * 0.4
- Depth = 4.5mm
- Screw quantity: 3 pieces

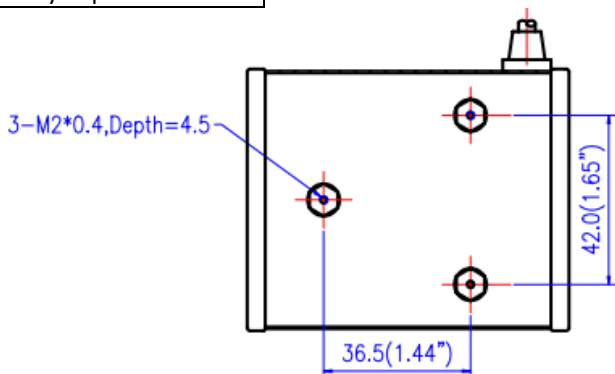

Figure 1: Screw Position

To ensure the scanner reaches its best performance, the following points need to be noticed when mounting the scanner:

- (a) Do not place the scanner under direct sunlight or any other bright light source illuminating.
- (b) When placing the barcode label, one must be careful not to over tilt, skew and/or pitch the barcode
- (c) Do not place the device at specula reflection position. The LED light of the scanner reflects directly back on the scanner if it is placed at specula reflection position. As to the nature of CCD sensor, it will not be able to read any barcodes.
- (d) The barcode label must be placed within the effective depth of field (D.O.F.) since it is the effective reading distance for the barcode from the scanner. For the best placing position, please refer to the Decode Depth of Field drawing (Figure 2).



Different quality and density of a barcode could effect the decode depth of field. Usually when a barcode has poor printing quality or high density, the depth of field would be shorter. It is highly suggested **not** place the barcode label at the extremes of depth of field as it is often easy to move out from the reading range.

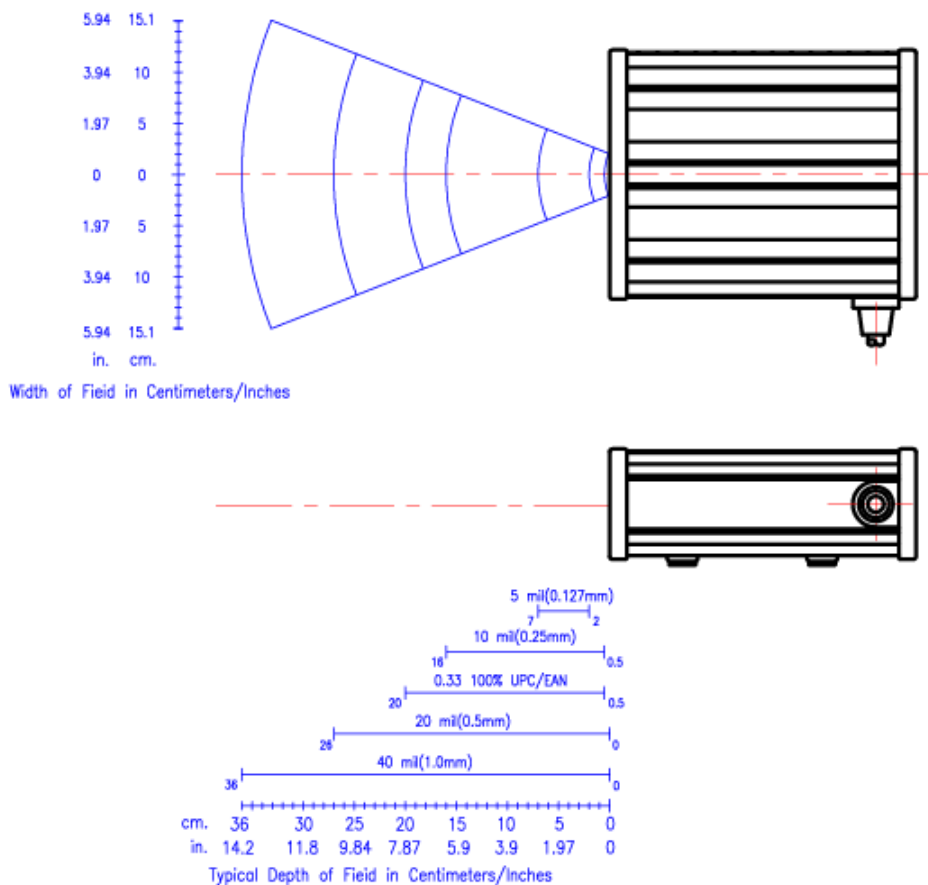

Figure 2: Decode Depth of Field

Connection

The scan module has 3 different kinds of interface connection to suit customer's desire; the standard cable is black, straight and 2m (6.5 feet) in length. Below shows the connector types and pin out configuration for each interface.

1. Keyboard Wedge connection for K/PS2 compatible terminal

K TYPE MINI DIN(M)+ MINI DIN(F)

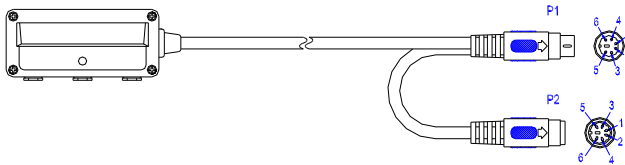

PIN-OUT CONFIGURATION			
MINI DIN (M)		MINI DIN(F)	
DIN	FUNATION	DIN	FUNATION
1	PC Data	1	KB Data
2	N.C.	2	N.C.
3	GND	3	GND
4	+5V	4	+5V
5	PC Clock	5	KB Clock
6	N.C.	6	N.C.

2. RS-232C interface uses detachable cable

Please select a suitable cable from the following options

DTE Pin-Out

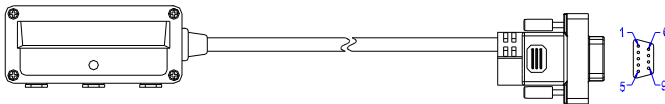

PIN-OUT CONFIGURATION			
2.	TX	7.	CTS
3.	RX	8.	RTS
5.	GND	9	+5V Input

DCE Pin-Out

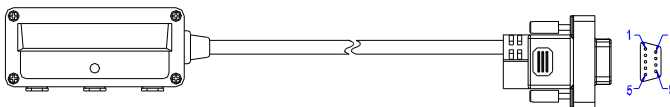

PIN-OUT CONFIGURATION			
2.	RX	7.	RTS
3.	RX	8.	CTS
5.	GND	9	+5V Input

RS-232 Interface with 2 Housing Connector

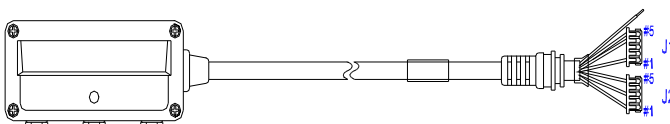

J1	FUNCTION	COLOR
#1	RTS	Grass
#5	CTS	Blue
#4	GND	Orange
#3	+5V	Red
#5	TX	Purple
#1	RX	Pink
	TRIGGER	WHITE

3. USB Interface/USB Virtual COM with Type A detachable cable

USB TYPE A
(Cable length: 1.5m)

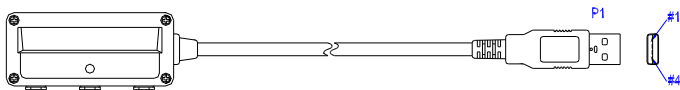

USB TYPE A CONNECTOR	FUNCTION
1.	VCC
2.	D-
3.	D+
4.	VSS

Technical Specification

<p>Power Requirement Input Voltage Power Consumption Operating Current</p>	<p>5V ±5% VDC 0.6 watts 120 mA</p>
<p>Operational Light Source Optical System Depth of Field Width of Field Scan Rate Minimum Bar Width Print Contrast Indicators (LED) Beeper Operation System Interface</p>	<p>617nm visible LED 2,500 pixels CCD 10 – 200 mm (UPC/EAN 100%, PCS=90%) 180 mm @ 200 mm of depth 150 scans per second 5mil @ PCS=90% 30% @ UPC/EAN 100% Two-color LED (green & red) Programmable tone & beep time Keyboard, RS-232C, HID USB,</p>
<p>Environment Operating Temperature Storage Temperature Humidity Ambient Light Immunity Drop Durability</p>	<p>0°C ~ 55°C (32°F ~ 131°F) -20°C ~ 60°C (-4°F ~ 140°F) 5% to 95% (non-condensing) Max. 4,500 Lux (fluorescence) Designed to withstand 1.0 m drops</p>
<p>Physical Dimension Height Width Depth Weight Mounting</p>	<p>30.25 mm (1.19") 65.0 mm (2.56") 80.0 mm (3.15") 150 g 3-M2 * 0.4 screw hole</p>
<p>Regulatory EMC</p>	<p>CE & FCC DOC compliance, VCCI, BSMI</p>
<p>Decode Symbology</p>	<p>UPC/JAN/EAN, UPC A & E, EAN-8, EAN-13, ISBN/ISSN, Code 39, Codabar, Code 128, EAN 128, Code 93, Interleave 2 of 5, Addendum 2 or 5, IATA Code, MSI/Plessey, Chinese Postal Code, Code 32 (Italian Pharmacode), Industrial 2 of 5, Standard 2 of 5</p>

Dimension

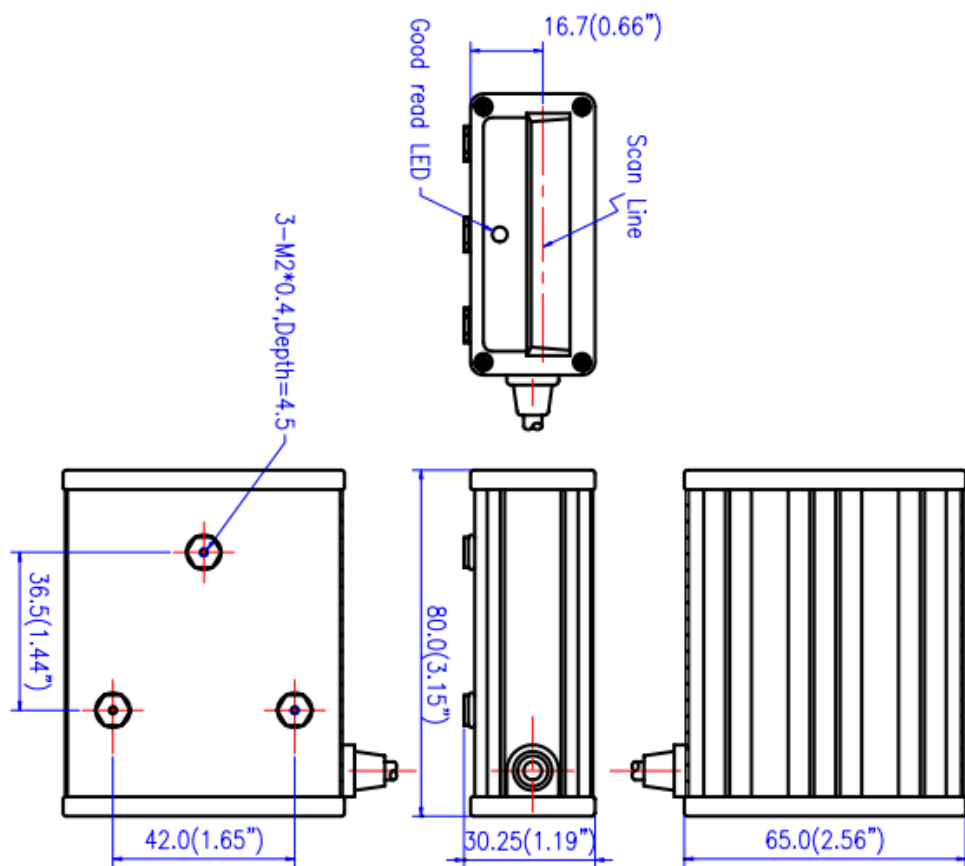

Maintaining the Scanner

The scanner is designed for long-term trouble-free operation and rarely requires any maintenance. Only an occasional cleaning of the scanner window is necessary in order to remove dirt and fingerprints.

Wipe the scan window with a soft lint-free cloth and a non-abrasive cleaner to avoid scratching and damaging the scan window. The scan window may be cleaned while the scanner is running.



Scratching the scanner window can reduce the scanning performance. It is suggested to either recess the window into the housing or apply a hard-coat on window.

Blink Mode

After the scanner has been inactive for a period of time, the light beam would automatically start blinking. To stop the scanner from blinking, simply present an object close to the scanner window or press the test button. The Blink Mode feature is included to reduce power consumption and to extend scanner life.

Programming Guide

Scanning a series of programming bar code labels can configure the scanner. This allows decoding options and interface protocols to be tailored to a specific application. The configuration is stored in non-volatile memory and will not be lost by removing power from the scanner.

The scanner must be properly powered before programming. For RS-232C type scanners, an external power adapter might be necessary to supply DC power to the scanner.

During the programming mode, the scanner will acknowledge a good and valid reading with a short beep. It will give long beeps for either an invalid or bad reading.

Table 1 gives the default settings of all the programmable parameters. The default settings will be restored whenever the "Reset" programming label is scanned.

Table 1: Factory Default Settings

Scanner Timing	Default
Same code delay	500ms
Scan mode	Auto scan
Blink mode timer	500ms
Power save	Off
RS-232 communication	Default
Baud rate	9600
Parity	none
Data bits	8
Stop bit	1
RTS/CTS	off
Terminator	<CR><LF>
USB Communication	Default
Terminator type	Enter
Code mode	Scan code
Decoder Selection	Default
EAN/UPC	Enable
CODE 39	Enable
Code 32	Disable
CODABAR	Enable
ITF 2 OF 5	Enable
MSI/Plessy	Disable
Chinese post code	Disable
Code 93	Enable
Code 128	Enable
EAN-128	Disable
Standard 2 of 5	Disable
NEC 2 of 5	Disable
Beeper sound	Default
Frequency	High
Duration	100 ms
Code Identifiers	Default
Code ID	Off
Code 39 identifier	M
ITF 2 of 5 identifier	I
Chinese post code identifier code	H
UPC-A identifier code	A
UPC-E identifier code	E
EAN-13 identifier code	F

Table 1: Factory Default Settings (Continued)

EAN-8 identifier code	FF
Codabar identifier code	N
Code 128 identifier code	K
Code 93 identifier code	L
MSI identifier code	P
Standard 2 of 5 identifier code	S
NEC 2 of 5 identifier code	G
LED/Beep transmission	Default
LED/beep before transmission	On

Table 2: Default Data Transmit Format

Code	Message format
EAN-13	D1 D2 D3 D4 D5 D6 D7 D8 D9 D10 D11 D12 D13
EAN-8	D1 D2 D3 D4 D5 D6 D7 D8
UPCA	D1 D2 D3 D4 D5 D6 D7 D8 D9 D10 D11 D12
UPCE	D1 D2 D3 D4 D5 D6 D7 D8
Code 128	D1-Dx (default 3~32)
EAN 128	C1 D1-Dx (default 3~32)
Code 39	D1-Dx (default 3~32)
Code 32	D1-Dx (default 3~32)
CODABAR	D1-Dx (default 6~32)
Interleaved 2 of 5	D1-Dx (default 6~32)
Chinese Post Code	D1-Dx (default 8~32)
Code 93	D1-Dx (default 3~32)
MSI	D1-Dx (default 6~32)
Coop 2 of 5	D1-Dx (default 6~32)

**Table 3: Trigger Command Format
(Only for RS-232C and USB-Virtual COM Port)**

Level Trigger Command	
Command	Description
<ESC>A0<CR>	<ul style="list-style-type: none"> ◆ When the scanner receives this command, the CCD/laser would light up and start scanning barcodes entering its scan field. ◆ The light would be switched off when the scanner receives a trigger off command.
Edge Trigger Command	
Command	Description
<ESC>A0.mm<CR>	<ul style="list-style-type: none"> ◆ When the scanner receives this command, the CCD/laser would light up and start scanning barcodes entering its scan field. ◆ The light would remain on until the scanner reads a barcode or until “mm” period is over (mm=01~60, unit: second). ◆ The edge trigger command is not controlled by the trigger off command.
<ESC>A2<CR>	<ul style="list-style-type: none"> ◆ When the scanner receives this command, the CCD/laser light would light up and remain on but the device can only scan once. ◆ The light would be switched off when the scanner receives a trigger off command.
<ESC>A2.mm<CR>	<ul style="list-style-type: none"> ◆ When the scanner receives this command, the CCD/laser light would light up and remain on until “mm” period is over. ◆ If the scanner read a barcode before “mm” period is over, the light-off countdown would re-start. ◆ The scanner is not controlled by the trigger off command.
Trigger Off Command	
Command	Description
<ESC>A1<CR>	<ul style="list-style-type: none"> ◆ The CCD/laser light would be switched off when the scanner receives a trigger off command.

Example:

- Sending <ESC> “A0” <CR> (0x1b 0x41 0x30 0x0d) to scan module will activate the module for scanning.
- Sending <ESC> “A1” <CR> (0x1b 0x41 0x31 0x0d) to scan module will turn off the scan.

Parameter setting



Default settings are highlighted in gray background.



Start Of Configuration

- Scan this barcode to enter set-up process.

System Function Setting



Reset

- Return to factory default



Display firmware version



Return as customer default



Save as customer default



Abort

-Exit programming mode (no update)



Power-up beeper tone enable



Power-up beeper tone disable



Speaker Disable



End Of Configuration



Start Of Configuration
- Scan this barcode to enter set-up process.



High beeper tone



Medium beeper tone



Low beeper tone



Loud volume



Medium volume



Slight volume



Good read beep sound duration (500ms)



Good read beep sound duration (200ms)



Good read beep sound duration (100ms)



Good read beep sound duration (50ms)



Good read beep sound duration (20ms)



Good read beep sound duration (5ms)



LED/Beep after transmission
- indicate a “good read” after a barcode is successfully decoded.



LED/Beep before transmission
- indicate a “good read” after successfully transmitting the barcode data to the host.



End Of Configuration

**Start Of Configuration**

- Scan this barcode to enter set-up process.

Scan Function Setting**Trigger mode**

- The scanner becomes inactive once the data is transmitted. It must be triggered to active again.

**Auto scan mode**

- The scanner will actively scan and decode barcodes, and the same barcode cannot be read twice.

**Light beam blinks when scanner enters blink mode****End Of Configuration**



Start Of Configuration

Power Save Mode Selection

Barcode Value	Barcode Label	Description
MT00		Power save mode off
MT01		Power save after 5 min
MT02		Power save after 10 min
MT03		Power save after 20 min
MT04		Power save after 30 min
MT05		Power save after 60 min
MT12		Power save after every trigger scan

***Power Save mode:** After the scanner has been inactive for a period of time, the device powers down to reduce power consumption.



End Of Configuration



Start Of Configuration
- Scan this barcode to enter set-up process.

Blink Setting

* Scan barcodes to set the time for switching to blink mode when the scanner is idle.

* Press the "Test" button to stop the blinking when the scanner enters blink mode.



Blink Mode off.
Light beam never enters blink mode



Light beam blink mode timer 5s



Light beam blink mode timer 10s



Light beam blink mode timer 15s



Light beam blink mode timer 20s



Light beam blink mode timer 30s



Light beam blink mode timer 60s



Light beam blinks in blink mode



End Of Configuration



Start Of Configuration
- Scan this barcode to enter set-up process.

Interface Setting



Enable USB-Virtual COM port



Enable HID USB keyboard



Enable RS-232 communication



Enable Keyboard wedge interface

HID USB Keyboard Wedge Setting



Enable Alt mode



Keyboard language support - USA



Keyboard language support - Japan



Capital lock on



Capital lock off



Function key emulation enable



Function key emulation disable



Send number as normal data



Send number as keypad data



End Of Configuration



Start Of Configuration

HID USB Keyboard Wedge Setting (Continued)



Alphabet follow as keyboard



Alphabet always upper case



Alphabet always lower case



Keyboard terminator - none



Keyboard terminator - enter



Keyboard terminator – H. Tab

RS-232 Interface Setting

Parity



Even parity



Odd parity



Mark parity



Space parity



None parity



End Of Configuration



Start Of Configuration

Baud Rate



Baud rate 115200



Baud rate 57600



Baud rate 38400



Baud rate 19200



Baud rate 9600



Baud rate 4800



Baud rate 2400



Baud rate 1200



Baud rate 600



Baud rate 300

Stop Bit



1 stop bit



2 stop bit



End Of Configuration



Start Of Configuration

Data Bit



7 data bit



8 data bit

Handshaking



None handshaking



ACK/NAK



Xon/Xoff



RTS/CTS (Character handshaking)



Standard CTS polarity

- high=inactive, do not send,
- low=active, do not send



Invert CTS polarity

- High=active, OK to send
- Low=inactive, do not send



Active RTS, do not wait for CTS



Active RTS, wait for CTS



RTS/CTS message handshaking



Enable beeper ON <BEL> character



Ignore beeper ON <BEL> character



End Of Configuration



Start Of Configuration

Handshaking (Continued)



ACK/NAK response time 500ms



ACK/NAK response time 300ms



ACK/NAK response time 5s



ACK/NAK response time 3s



ACK/NAK response time 2s



ACK/NAK response time 1s



ACK/NAK response time infinity



End Of Configuration



Start Of Configuration

Message Terminator



RS-232 message terminator – none



RS-232 message terminator – CR/LF



RS-232 message terminator – CR



RS-232 message terminator – LF



RS-232 message terminator – H tab



RS-232 message terminator – STX/ETX



RS-232 message terminator – EOT



End Of Configuration



Start Of Configuration

The Symbologies Setting

Codabar



Codabar enable



Codabar disable



Codabar start/stop character transmission – None



Codabar start/stop character transmission – A,B,C,D



Codabar start/stop character transmission – DC1~DC4



Codabar start/stop character transmission –
a/t, b/n, c/*, d/e



Codabar maximum length setting



Codabar minimum length setting



Save setting to confirm (for length setting)



Codabar concatenation disable



Codabar concatenation enable



No check character



Validate modulo 16, but don't transmit



End Of Configuration



Start Of Configuration

Codabar (Continued)



Validate modulo 16, but transmit



Codabar data redundant check=off



Codabar data redundant check=1



Codabar data redundant check=2



Codabar data redundant check=3

Code 39



Code 39 enable



Code 39 disable



Code 32 enable



Code 32 disable



Code 39 data redundant check=off



Code 39 data redundant check=1



Code 39 data redundant check=2



Code 39 data redundant check=3



End Of Configuration



Start Of Configuration

Code 39(Continued)



Standard code 39



Full ASCII code 39



Code 39 start/stop character transmission



Code 39 start/stop character without transmission



Code 39 check digit calculate and transmit



Code 39 check digit calculate but without transmit



No check character



Code 39 maximum length setting



Code 39 minimum length setting



Save setting to confirm (for length setting)



End Of Configuration



Start Of Configuration

Code 39 (Continued)



Code 39 concatenation enable



Code 39 concatenation disable



Code 32 (Italian pharmacy) transmit "A" character



Code 32 (Italian pharmacy) without transmit "A" character

Code 93



Code 93 enable



Code 93 disable



Code 93 data redundant check=off



Code 93 data redundant check=1



Code 93 data redundant check=2



Code 93 data redundant check=3



Code 93 maximum length setting



Code 93 minimum length setting



Save setting to confirm (for length setting)



End Of Configuration



Start Of Configuration

Code 93 (Continued)



Code 93 check digit calculated but without transmit



Code 93 check digit not calculated and without transmit



Code 93 check digit calculated and transmit

Code 128



Code 128 enable



Code 128 disable



EAN-128 enable



EAN-128 disable



Code 128 data redundant check=off



Code 128 data redundant check=1



Code 128 data redundant check=2



Code 128 data redundant check=3



Code128 FNC2 concatenation enable



Code128 FNC2 concatenation disable



End Of Configuration



Start Of Configuration

Code 128 (Continued)



No check character



Calculate but not transmit



Calculate and transmit



Code 128 maximum length setting



Code 128 minimum length setting



Save setting to confirm (for length setting)

Chinese Post Code



Chinese post code enable



Chinese post code disable



Chinese post code data redundant check=off



Chinese post code data redundant check=1



Chinese post code data redundant check=2



Chinese post code data redundant check=3



End Of Configuration



Start Of Configuration

Chinese Post Code(Continued)



Chinese post code maximum length setting



Chinese post code minimum length setting



Chinese post code no check digit



Chinese post code check digit calculate and transmit



Chinese post code check digit calculate but without transmit



Save setting to confirm (for length setting)

MSI/Plessy



MSI enable



MSI disable



MSI data redundant check= off



MSI data redundant check=1



MSI data redundant check=2



MSI data redundant check=3



End Of Configuration



Start Of Configuration

MSI/Plessy (Continued)



MSI/PLESSY maximum length setting



MSI/PLESSY minimum length setting



Save setting to confirm (for length setting)



MSI/Plessy double check digit calculate but not transmit



MSI/Plessy double check digit without calculate and transmit



MSI/Plessy double check digit calculate but only first digit transmit



MSI/Plessy double check digit calculate and both transmit



MSI/Plessy single check digit calculate but without transmit



MSI/Plessy single check digit calculate and transmit



End Of Configuration



Start Of Configuration

Interleave 2 of 5



ITF 2 of 5 enable



ITF 2 of 5 disable



IATA code enable



IATA disable



ITF 2 of 5 data redundant check=off



ITF 2 of 5 data redundant check=1



ITF 2 of 5 data redundant check=2



ITF 2 of 5 data redundant check=3



ITF 2 of 5 code maximum length setting



ITF 2 of 5 code minimum length setting



Save setting to confirm (for length setting)



ITF 2 of 5 no check character



ITF 2 of 5 check digit calculate and transmit



ITF 2 of 5 check digit calculate but without transmit



End Of Configuration



Start Of Configuration

Interleave 2 of 5 (Continued)



ITF 2 of 5 one fixed length setting



ITF 2 of 5 two fixed length setting

UPC/EAN/JAN



EAN convert to ISSN/ISBN enable



EAN convert to ISSN/ISBN disable



UPC/EAN/JAN enable



UPC/EAN/JAN disable



UPC/EAN/JAN all enable



EAN-8 or EAN-13 enable



UPC-A and EAN-13 enable



UPC-A and UPC-E enable



UPC-A enable



UPC-E enable



EAN-13 enable



EAN-8 enable



End Of Configuration



Start Of Configuration

UPC/EAN/JAN (Continued)



UPC/EAN add on off



Add on 5 only



Add on 2 only



Add on 2 or 5



Force UPC-E to UPC-A format enable



Force UPC-E to UPC-A format disable



Force UPC-A to EAN-13 format enable



Force UPC-A to EAN-13 format disable



Transmit UPC-A check digit enable



Transmit UPC-A check digit disable



Transmit UPC-E leading character enable



Transmit UPC-E leading character disable



Transmit UPC-E check digit enable



Transmit UPC-E check digit disable



End Of Configuration



Start Of Configuration

UPC/EAN/JAN (Continued)



Transmit EAN-8 check digit enable



Transmit EAN-8 check digit disable



Transmit EAN-13 check digit enable



Transmit EAN-13 check digit disable



Transmit UPC-A leading character enable



Transmit UPC-A leading character disable



Add on format with separator



Add on format without separator



EAN/UPC +add on (none mandatory)



EAN/UPC +add on (mandatory)



Force EAN-8 to EAN-13 format enable



Force EAN-8 to EAN-13 format disable



EAN-13 first "0" can transmitted



EAN-13 first:"0" can't transmitted



End Of Configuration



Start Of Configuration

UPC/EAN/JAN (Continued)



EAN-13 with first 0 ID code same as "UPC-A"

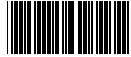

EAN-13 with first 0 ID code same as "EAN-13"



EAN/UPC +add on mandatory 491 Japanese (bookland)
Supplement requirement, optionally for other



EAN/UPC +add on mandatory for 491 Japanese (bookland)
Supplement requirement, not sent for other



EAN/UPC +add on mandatory for 978/977 (bookland)
Supplement requirement, optionally for other

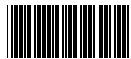

EAN/UPC +add on mandatory for 978/977 (bookland)
Supplement requirement, not sent for other

Data Editing



Code 39 identifier code setting



ITF 2 of 5 identifier code setting



Chinese Post Code identifier code setting



UPC-E identifier code setting



UPC-A identifier code setting



EAN-13 identifier code setting



End Of Configuration



Start Of Configuration

Data Editing (Continued)



EAN-8 identifier code setting



Codabar identifier code setting



Code 128 identifier code setting



Code 93 identifier code setting



MSI identifier code setting



Standard 2 of 5 identifier code setting



Coop 2 of 5 identifier code setting (For specific model only)



Add code length as header enable (all barcode)



Add code length as header disable (all barcode)



Header (preamble)



Trailer (postamble)



Save setting to confirm (for length setting)



Truncate header character



Truncate trailer character



End Of Configuration



Start Of Configuration

Data Editing (Continued)



Inter character delay 100ms



Inter character delay 90ms



Inter character delay 50ms



Inter character delay 20ms



Inter character delay 10ms



Inter character delay 5ms



Inter character delay 2ms



Inter character delay 0ms



Inter message delay 1000ms



Inter message delay 500ms



Inter message delay 100ms



Inter message delay 0ms



Disable identifier code



Enable identifier code table as manufacturer standard



End Of Configuration



Start Of Configuration

Standard 2 of 5



Standard 2 of 5 code enable



Standard 2 of 5 code disable



Standard 2 of 5 code maximum length setting

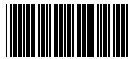

Standard 2 of 5 code minimum length setting



Save setting to confirm (for length setting)



Standard 2 of 5 code no check character



Standard 2 of 5 code check digit calculate and transmit



Standard 2 of 5 code check digit calculate but without transmit



End Of Configuration



Start Of Configuration

Industrial 2 of 5



Industrial 2 of 5 code enable



Industrial 2 of 5 code disable



Industrial 2 of 5 code maximum length setting



Industrial 2 of 5 code minimum length setting



Save setting to confirm (for length setting)



Industrial 2 of 5 code no check character



Industrial 2 of 5 code check digit calculate and transmit



Industrial 2 of 5 code check digit calculate but without transmit



End Of Configuration



Start Of Configuration

Code 39 Full ASCII Table

Code 39	ASCII	Hexa-c ode	Code 39	ASCII	Hexa-c ode
	Full ASCII ---NUL	00		Full ASCII ---SI Function key----"Shift"	0F
	Full ASCII ---SOH Function key----"Ins"	01		Full ASCII ---DLE Function key----"5(num)"	10
	Full ASCII ---STX Function key----"Del"	02		Full ASCII ---DC1 Function key----"F1"	11
	Full ASCII ---ETX Function key----"Home"	03		Full ASCII ---DC2 Function key----"F2"	12
	Full ASCII ---EOT Function key----"End"	04		Full ASCII ---DC3 Function key----"F3"	13
	Full ASCII ---ENQ Function key----"Up arrow"	05		Full ASCII ---DC4 Function key----"F4"	14
	Full ASCII ---ACK Function key----"Down arrow"	06		Full ASCII ---NAK Function key----"F5"	15
	Full ASCII ---BEL Function key----"Left arrow"	07		Full ASCII ---SYN Function key----"F6"	16
	Full ASCII ---BS Function key----"Backspace"	08		Full ASCII ---ETB Function key----"F7"	17
	Full ASCII ---HT Function key----"TAB"	09		Full ASCII ---CAN Function key----"F8"	18
	Full ASCII ---LF Function key----"Enter (alpha numeric)"	0A		Full ASCII ---EN Function key----"F9"	19
	Full ASCII ---VT Function key----"right arrow"	0B		Full ASCII ---SUB Function key----"F10"	1A
	Full ASCII ---FF Function key----"PgUp"	0C		Full ASCII ---ESC Function key----"F11"	1B
	Full ASCII ---CR Function key----"Enetr(num.)"	0D		Full ASCII ---FS Function key----"F12"	1C
	Full ASCII ---SO Function key----"PgDn"	0E		Full ASCII ---GS Function key----"ESC"	1D



End Of Configuration



Start Of Configuration

Code 39 Full ASCII Table (Continued)

Code 39	ASCII	Hexa-code	Code 39	ASCII	Hexa-code
	Full ASCII ---RS Function key-----“CTL(L)”	1E		Full ASCII ----	2D
	Full ASCII ---US Function key-----“ALT(L)”	1F		Full ASCII ---.	2E
	Full ASCII ---SP	20		Full ASCII ---/	2F
	Full ASCII ---!	21		Full ASCII ---0	30
	Full ASCII ---“	22		Full ASCII ---1	31
	Full ASCII ---#	23		Full ASCII ---2	32
	Full ASCII ---\$	24		Full ASCII ---3	33
	Full ASCII ---%	25		Full ASCII ---4	34
	Full ASCII ---&	26		Full ASCII ---5	35
	Full ASCII ---’	27		Full ASCII ---6	36
	Full ASCII --- (28		Full ASCII ---7	37
	Full ASCII ---)	29		Full ASCII ---8	38
	Full ASCII ---*	2A		Full ASCII ---9	39
	Full ASCII ---+	2B		Full ASCII ---:	3A
	Full ASCII ---,	2C		Full ASCII ---;	3B



End Of Configuration



Start Of Configuration

Code 39 Full ASCII Table (Continued)

Code 39	ASCII	Hexa-code	Code 39	ASCII	Hexa-code
	Full ASCII ---RS Function key-----"CTL(L)"	1E		Full ASCII ----	2D
	Full ASCII ---US Function key-----"ALT(L)"	1F		Full ASCII ---.	2E
	Full ASCII ---SP	20		Full ASCII ---/	2F
	Full ASCII ---!	21		Full ASCII ---0	30
	Full ASCII ---"	22		Full ASCII ---1	31
	Full ASCII ---#	23		Full ASCII ---2	32
	Full ASCII ---\$	24		Full ASCII ---3	33
	Full ASCII ---%	25		Full ASCII ---4	34
	Full ASCII ---&	26		Full ASCII ---5	35
	Full ASCII ---'	27		Full ASCII ---6	36
	Full ASCII --- (28		Full ASCII ---7	37
	Full ASCII ---)	29		Full ASCII ---8	38
	Full ASCII ---*	2A		Full ASCII ---9	39
	Full ASCII ---+	2B		Full ASCII ---:	3A
	Full ASCII ---,	2C		Full ASCII ---;	3B



End Of Configuration



Start Of Configuration

Code 39 Full ASCII Table (Continued)

Code 39	ASCII	Hexa-c ode	Code 39	ASCII	Hexa- code
	Full ASCII ---<	3C		Full ASCII ---K	4B
	Full ASCII ---=	3D		Full ASCII ---L	4C
	Full ASCII --->	3E		Full ASCII ---M	4D
	Full ASCII ---?	3F		Full ASCII ---N	4E
	Full ASCII ---@	40		Full ASCII ---O	4F
	Full ASCII ---A	41		Full ASCII ---P	50
	Full ASCII ---B	42		Full ASCII ---Q	51
	Full ASCII ---C	43		Full ASCII ---R	52
	Full ASCII ---D	44		Full ASCII ---S	53
	Full ASCII ---E	45		Full ASCII ---T	54
	Full ASCII ---F	46		Full ASCII ---U	55
	Full ASCII ---G	47		Full ASCII ---V	56
	Full ASCII ---H	48		Full ASCII ---W	57
	Full ASCII ---I	49		Full ASCII ---X	58
	Full ASCII ---J	4A		Full ASCII ---Y	59



End Of Configuration



Start Of Configuration

Code 39 Full ASCII Table (Continued)

Code 39	ASCII	Hexa-code	Code 39	ASCII	Hexa-code
	Full ASCII ---Z	5A		Full ASCII ---i	69
	Full ASCII ---[5B		Full ASCII ---j	6A
	Full ASCII ---\	5C		Full ASCII ---k	6B
	Full ASCII ---]	5D		Full ASCII ---l	6C
	Full ASCII ---^	5E		Full ASCII ---m	6D
	Full ASCII ---_	5F		Full ASCII ---n	6E
	Full ASCII ---`	60		Full ASCII ---o	6F
	Full ASCII ---a	61		Full ASCII ---p	70
	Full ASCII ---b	62		Full ASCII ---q	71
	Full ASCII ---c	63		Full ASCII ---r	72
	Full ASCII ---d	64		Full ASCII ---s	73
	Full ASCII ---e	65		Full ASCII ---t	74
	Full ASCII ---f	66		Full ASCII ---u	75
	Full ASCII ---g	67		Full ASCII ---v	76
	Full ASCII ---h	68		Full ASCII ---w	77



End Of Configuration



Start Of Configuration

Code 39 Full ASCII Table (Continued)

Code 39	ASCII	Hexa- code	Code 39	ASCII	Hexa- code
	Full ASCII ---x	78		Full ASCII ---	7C
	Full ASCII ---y	79		Full ASCII ---}	7D
	Full ASCII ---z	7A		Full ASCII ---~	7E
	Full ASCII ---{	7B		Full ASCII ---DEL	7F



End Of Configuration