

# User's Manual

2D Image Fixed Industrial Scanner

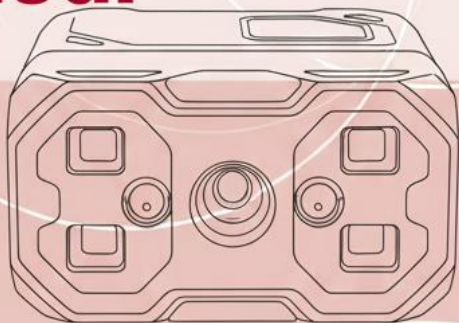



**Revision History**

Changes to the original manual are listed below:

<b>Version</b>	<b>Date</b>	<b>Description of Version</b>
1.0	09/19/2025	Initial release

# Important Notice

No warranty of any kind is made in regard to this material, including, but not limited to, implied warranties of merchantability or fitness for a particular purpose. We are not liable for any errors contained herein or incidental or consequential damages in connection with furnishing, performance or use of this material.

No part of this document may be reproduced, transmitted, stored in a retrieval system, transcribed, or translated into any language or computer language in any form or by any means electronic, mechanical, magnetic, optical, chemical, manual or otherwise, without express written consent and authorization.

We reserve the right to make changes in product design without reservation and without notification. The material in this guide is for information only and is subject to change without notice.

All trademarks mentioned herein, registered or otherwise, are the properties of their various respective owners.

Copyright © 2025. All rights reserved.

## Guidance for Printing

This manual is in A5 size. Please double check your printer setting before printing it out.

**Adjustments:** Do not attempt any adjustments or alteration of this product. Do not remove the protective housing of the scanner. There are no user-serviceable parts inside.

**Optical:** The use of optical instruments with this product will increase the eye hazard. Optical instruments include binoculars, magnifying glasses, and microscopes but do not include normal eye glasses worn by the user.

**CAUTION: Use of controls or adjustments or performance of procedures other than those specified herein may result in hazardous radiation exposure.**

## For CE-countries

This scanner is in conformity with CE standards. Please note that an approved, CE-marked power supply unit should be used in order to maintain CE conformance.

# Table of Contents

Important Notice.....	ii
Product Overview.....	1
Product Description .....	1
Key Features .....	2
Device Overview .....	3
<b>Indicator Functions</b> .....	4
Connections and Wiring.....	5
Accessories .....	6
<b>Dimension</b> .....	6
Setup & Operation .....	7
Installing the Device .....	7
Power Connection.....	9
Communication Connection .....	10
<b>RS-232 Serial Port</b> .....	10
<b>Ethernet Connection</b> .....	11
I/O Wiring Guide .....	12
Overview .....	12
Input Electrical Characteristics .....	12
Output Electrical Characteristics .....	12
Internal Wiring .....	13
<b>Input Circuit</b> .....	13
<b>Output Circuit</b> .....	14
External I/O Wiring .....	15
<b>Input Wiring</b> .....	15
<b>Output Wiring</b> .....	16
RS-232 Serial Port.....	17
Client Operation .....	18
Software Connection.....	18
PC Network Configuration.....	19
Changing the PC IP Address.....	19
Changing the Barcode Reader IP Address .....	21
Firmware Upgrade .....	22
Function Overview .....	23
Interface Overview .....	23
Code Reading Configuration.....	24
Template Selection.....	24
Image Acquisition.....	25
Adaptive Parameter Adjustment.....	26
Camera Settings .....	27

Light Source Settings .....	28
Algorithm Configuration .....	29
Code Reading Type .....	29
Algorithm Parameters .....	30
ROI (Region of Interest) Settings .....	31
Manual ROI .....	32
Batch ROI (Checkerboard) .....	33
Clear All ROIs .....	34
Trigger Configuration .....	35
Trigger Types .....	35
Continuous Trigger .....	36
I/O Trigger .....	37
Start Trigger .....	38
End Trigger .....	38
Software Trigger .....	39
Network Trigger .....	39
Format Configuration .....	40
Data Filtering .....	41
Communication Configuration .....	45
TCP Server .....	45
Modbus TCP .....	46
MC Protocol .....	47
Serial Protocol .....	48
Modbus RTU .....	49
Device Management .....	50
Settings .....	51
Device Settings .....	51
Firmware Update .....	52
Backup & Restore .....	52
Log .....	52
Storage Settings .....	53
Frequently Asked Questions .....	54

# Product Overview

## Product Description

---

The **ZX-1060 Intelligent Code Reader** is a versatile device designed for industrial applications, including:

- Electronics
- Food and pharmaceuticals
- Semiconductor manufacturing
- Automotive production
- Spare parts and other industries

The ZX-1060 captures images of objects using integrated sensors and optical components then processes them with its internal barcode recognition algorithm. Test results can also be transmitted via multiple communication interfaces.

## Key Features

- **Compact design:** ideal for installation in tight spaces.
- **Advanced liquid lens with auto-focus:** enables fast zooming and precise focusing.
- **One-touch parameter tuning:** the Tune button automatically optimizes settings, saving setup time.
- **High-precision barcode reading:** supports ultra-small codes at various distances.
- **Simplified wiring:** aviation plug design allows single-cable connection.

# Device Overview

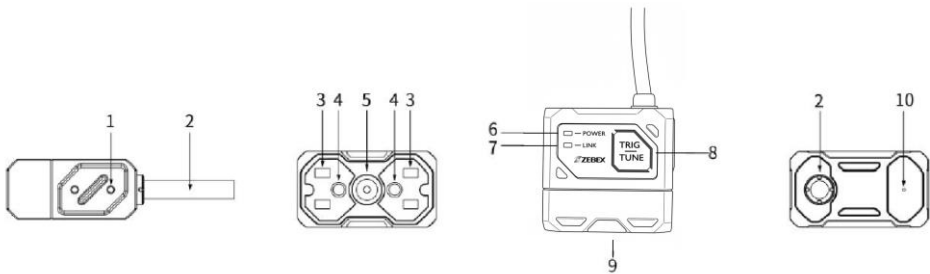

#	Component	Function
1	Mounting hole	Secures the ZX-1060 to a surface or bracket.
2	Connecting wires	M12-17PIN cable port; connects power, Ethernet interfaces, and handles IO lines and serial communication.
3	Light source	White LED illumination for image capture.
4	Aiming light	Indicates image center for easier targeting.
5	Image sensor	Captures images for processing.
6	Power indicator	Green = operating normally; OFF = inactive.
7	Network indicator	Flashes green when network communication is active.
8	TRIG/TUNE button	Single press: capture image. Hold 5 seconds: auto-adjust parameters.
9	Status indicator	Green = successful read; Red = failed read. Includes audio feedback.
10	Buzzer	Provides an audible alert when decoding succeeds or fails

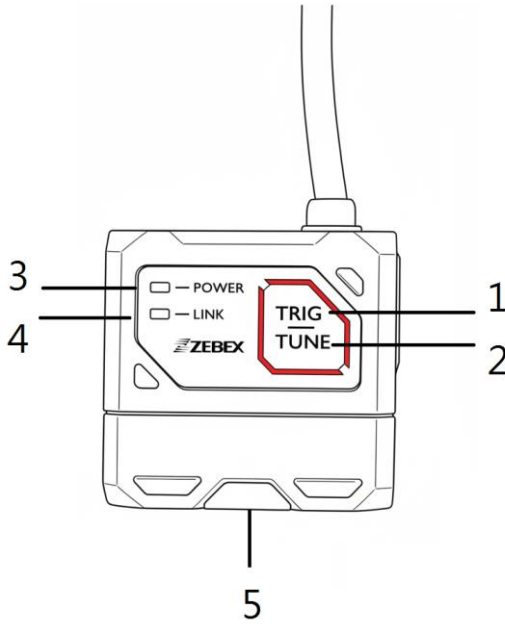

### Indicator Functions

#	Indicator	Meaning
1	TRIG	Triggers image capture.
2	TUNE	Automatic parameter adjustment.
3	Power	Green = device running normally.
4	Network	Flashes green when network is active.
5	Status (OK/NG)	Green = code read successfully; Red = read failed.

## Connections and Wiring

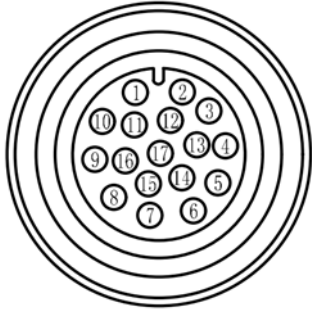
M12–17 Pin Male Connector		Pin	Wire Color	Signal
		1	Red	DC 24V
		2		Not used
		3		Not used
		4	Red/Blue	RS232 TXD
		5	Light Green	RS232 RXD
		6	White/Orange	ENET RX-
		7	Green	ENET TX+
		8	Yellow	LINE_IN0
		9	Brown	IN_COM
		10	White	LINE_IN1
		11	Black	GND
		12	Gray	LINE_OUT0
		13		Not used
		14	Orange	ENET RX+
		15	Green/White	ENET TX-
		16	Purple	LINE_OUT1
		17	Blue	LINE_OUT2

## Accessories

Item	Description
M12-17PIN Cable	Connects device to power and interfaces.
L-Shaped Mounting Bracket	Includes bracket and screws for installation.

## Dimension

Unit: mm

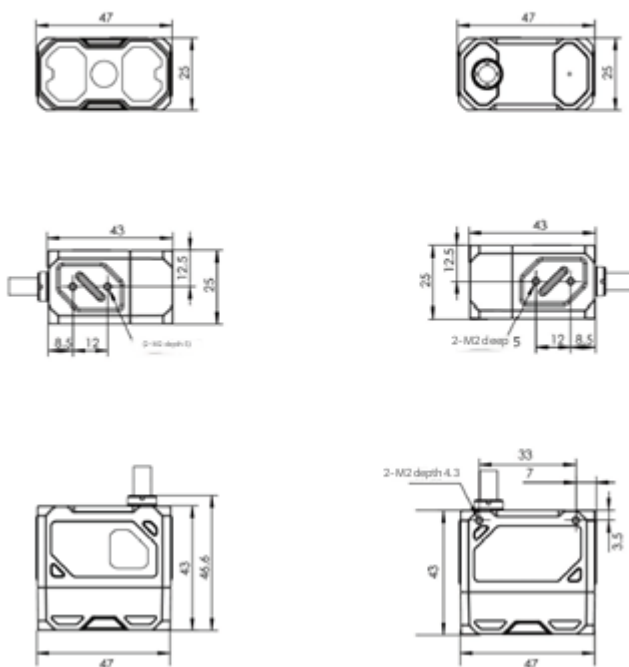

# Setup & Operation

## Installing the Device

---

- Secure the ZX-1060 to the mounting bracket using screws.
- Attach the bracket to the surface or component.
- **Tip:** Install at a 10–15° angle to avoid glare.
- **Working distance:** Liquid zoom: 40–300 mm; Manual zoom: 30–300 mm

*(Refer to diagrams below for installation and field-of-view.)*

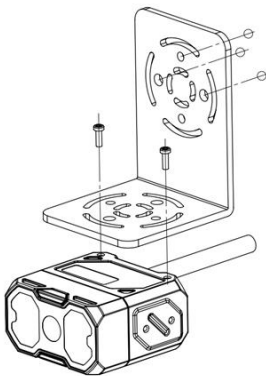

Front View Install



Side View Install

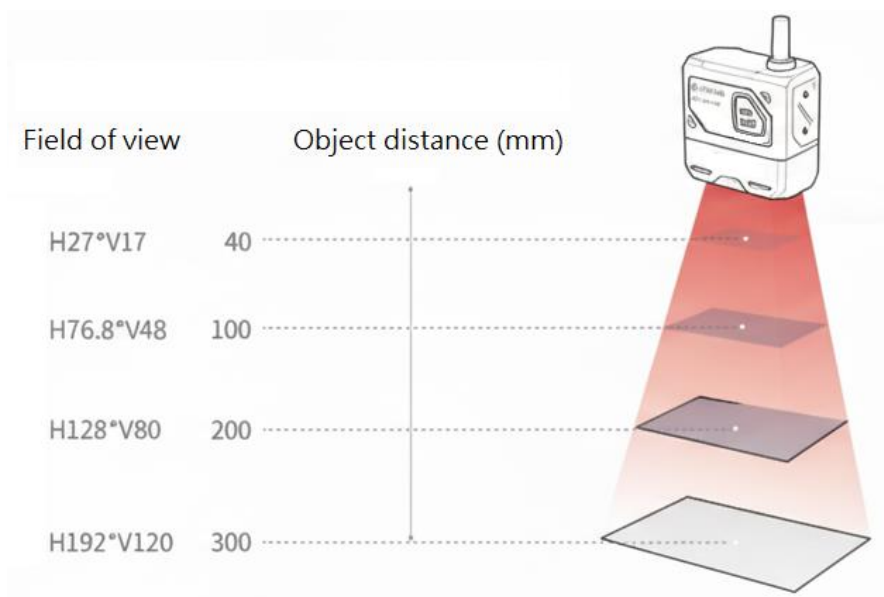

Liquid Lens Zoom Field of View

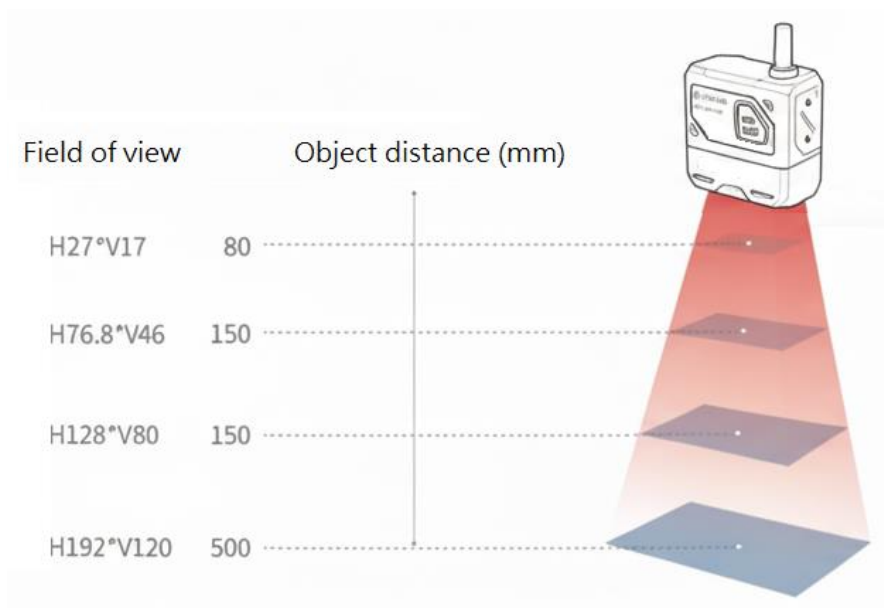

Manual Zoom Field of View

## Power Connection

- Operating voltage: 24V DC, max 3A
- Connection options: 110V~220V AC via adapter (optional accessory)

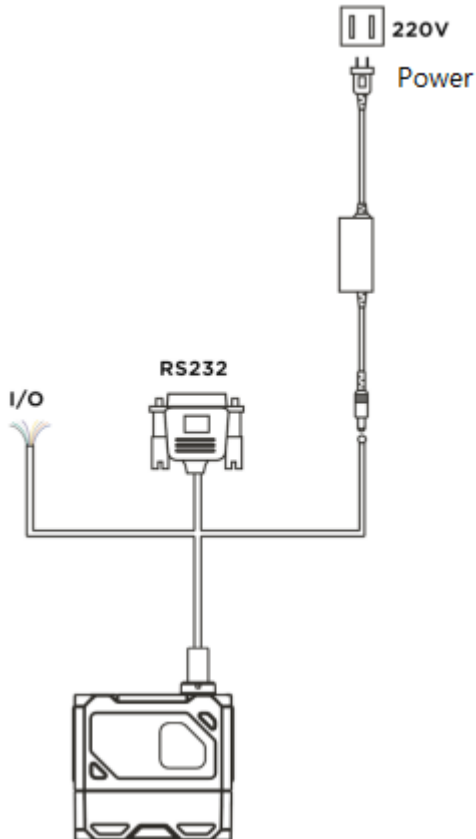

## Communication Connection

### RS-232 Serial Port

- Default: 9600 baud, 8 data bits, no parity, 1 stop bit
- Settings can be adjusted during software configuration

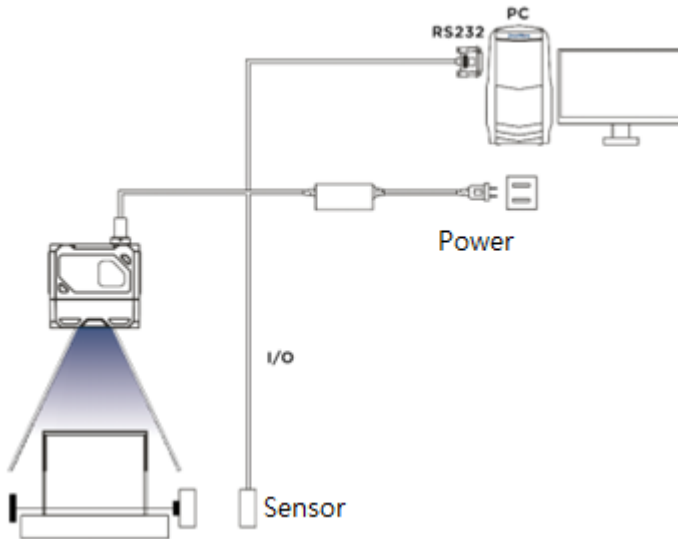

## Ethernet Connection

- Default IP: 169.254.153.0
- Default port: 15000

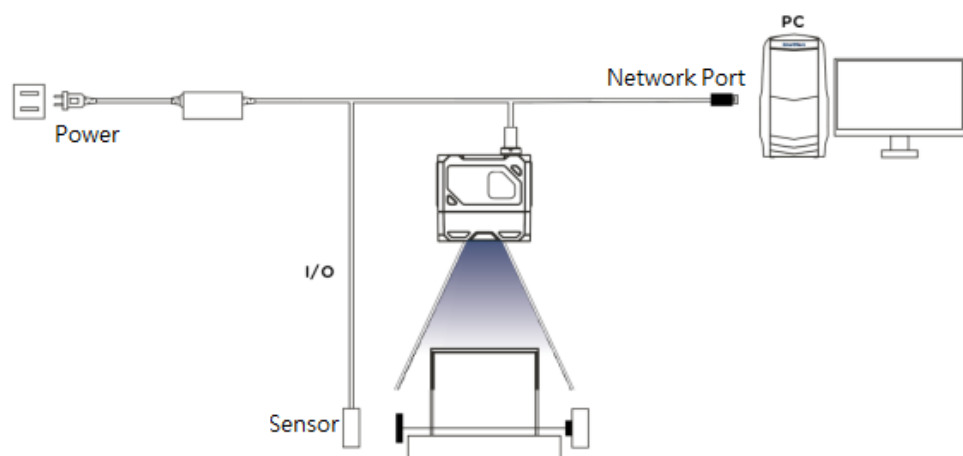

# I/O Wiring Guide

---

## Overview

- 2 optocoupler-isolated inputs
- 3 non-isolated outputs

## Input Electrical Characteristics

Parameter	Symbol	Value
Input logic low voltage	VOL	8V
Input logic high voltage	VOH	12V
Input falling edge delay	TDF	10 $\mu$ s
Input rising edge delay	TDR	47 $\mu$ s

*Note:* Logic low/high = voltage threshold. Rise/fall delays indicate performance.

## Output Electrical Characteristics

Parameter	Symbol	Value
Output logic low voltage	VOL	0.7V
Output logic high voltage	VOH	23.9V
Output falling edge delay	TDF	20.3 $\mu$ s
Output rising edge delay	TDR	550 $\mu$ s
Output fall time	TF	12 $\mu$ s
Output rise time	TR	3.5 $\mu$ s

- Output voltage range: 5–40V
- Max output current: 50 mA

# Internal Wiring

## Input Circuit

- LineIn0 / LineIn1: optocoupler-isolated
- Voltage range: 8–24V DC

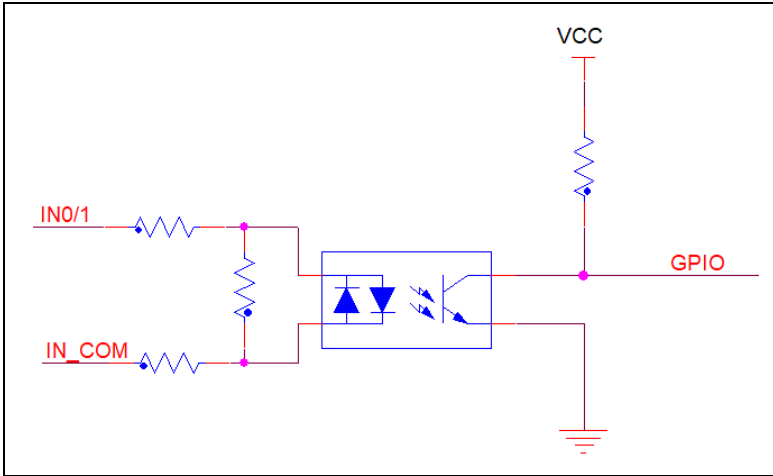

Device Input Circuit Diagram

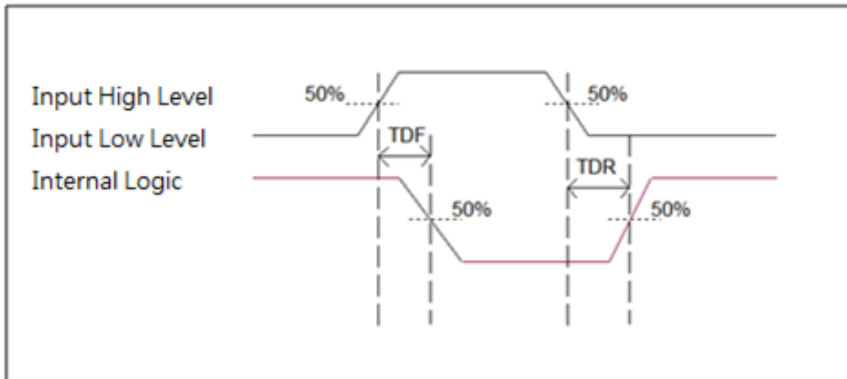

Input Logic Level Diagram

## Output Circuit

- LineOut0 / LineOut1 / LineOut2: non-isolated
- Voltage range: 5–40V, max current 50 mA

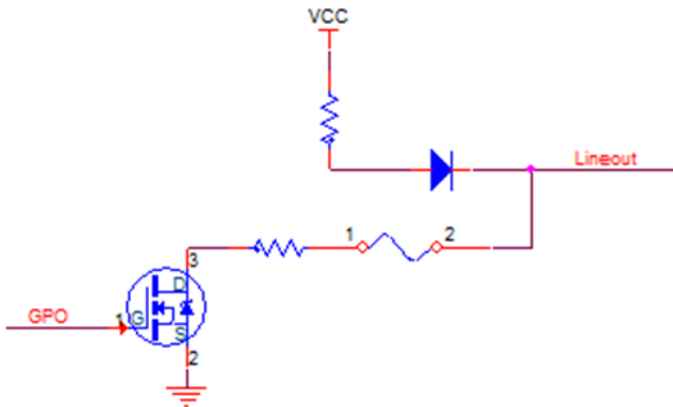

Device Output Circuit Diagram

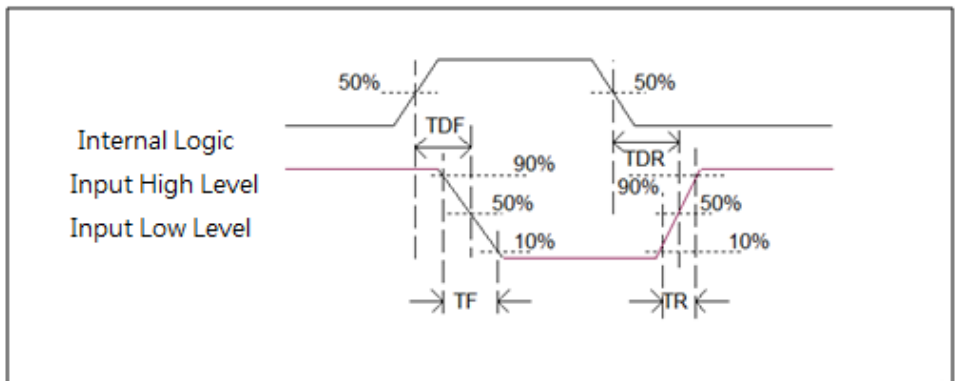

Output Logic Level Diagram

## External I/O Wiring

### Input Wiring

- Depends on external device type
- Examples: NPN or PNP input

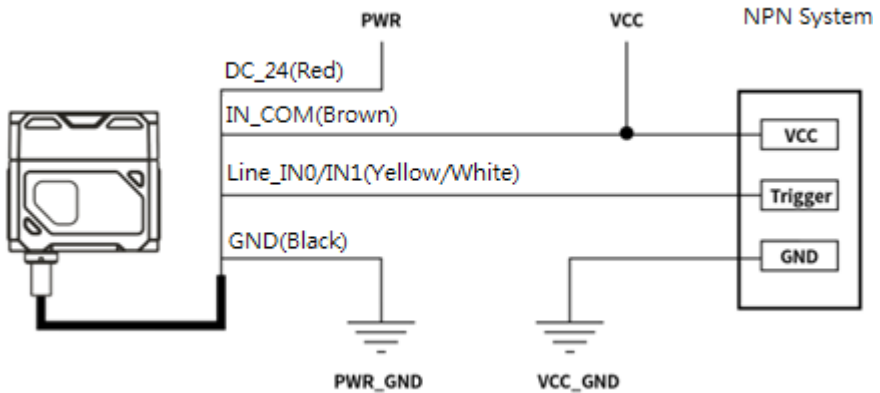

NPN as input

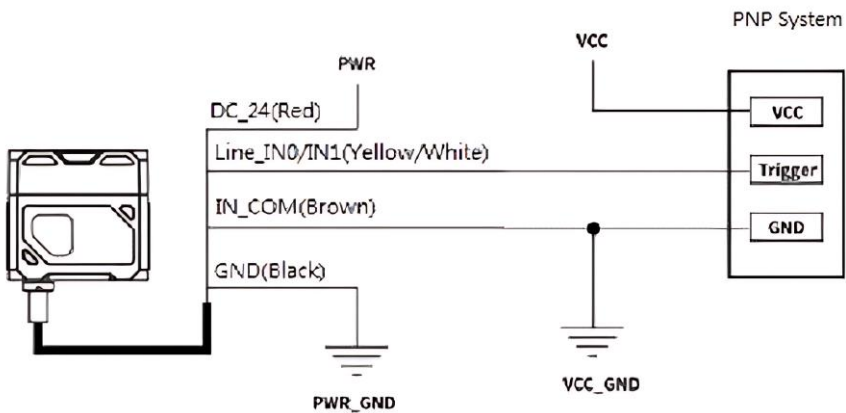

PNP as input

## Output Wiring

- Depends on external device type
- Example: NPN device

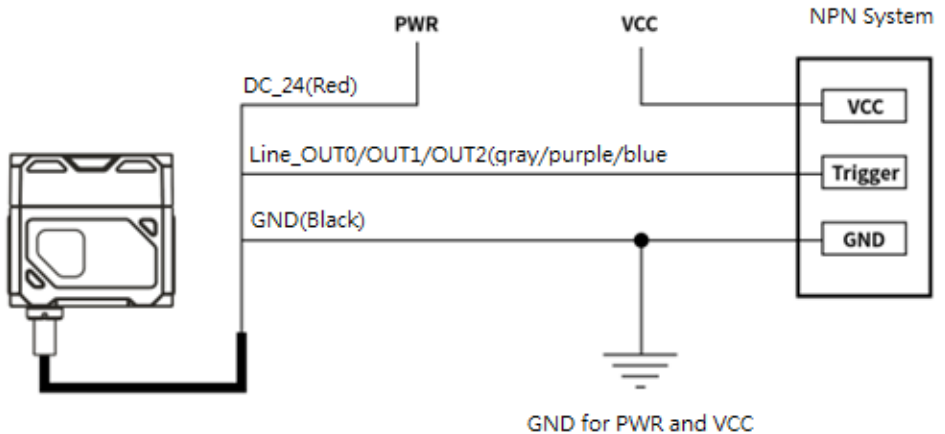

NPN as external device

### Guidelines:

1. VCC must not exceed PWR voltage by more than 24V.
2. Output load must comply with specifications. Use a current-limiting resistor if needed.

## RS-232 Serial Port

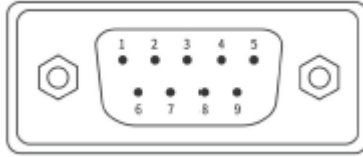

- Supports 9-pin male RS-232 connector for external communication
- VCC must not exceed PWR voltage to prevent abnormal output

Pin	Function	Description
2	RX	Receive data
3	TX	Transmit data
5	GND	Signal Ground

# Client Operation

## Software Connection

---

- Double-click the software icon to launch the client.
- Ensure that the ZX-1060 intelligent barcode reader and the PC running the configuration software are within the same network segment.
- Default IP address: **169.254.153.0**; Subnet Mask: **255.255.0.0**
- You can connect using either **DHCP** or a **static IP address**.

The screenshot shows a dialog box titled "IP configuration". It has two main sections. The first section, "Setting mode", contains two radio buttons: "Use DHCP" (which is unselected) and "Use static IP" (which is selected). The second section, "Static IP configuration", contains a "One-click matching" button, a "Configuration...." dropdown menu, and two input fields. The "IP address" field contains the text "192 . 168 . 168 . 2" and the "Subnet mask" field contains "255 . 255 . 255 . 0". Below these fields is a blue link labeled "more". At the bottom of the dialog box are two buttons: "Cancel" and "Confirm".

# PC Network Configuration

## Changing the PC IP Address

Using Windows 10 as an example:

1. Navigate to: **Start Menu > Settings > Network & Internet > Ethernet > Adapter Options.**
2. Right-click **Ethernet 3 > Properties > Internet Protocol Version 4 (TCP/IPv4).**
3. Modify the IP address of the corresponding network card to:
  - **IP Address:** 169.254.153.16
  - **Subnet Mask:** 255.255.0.0

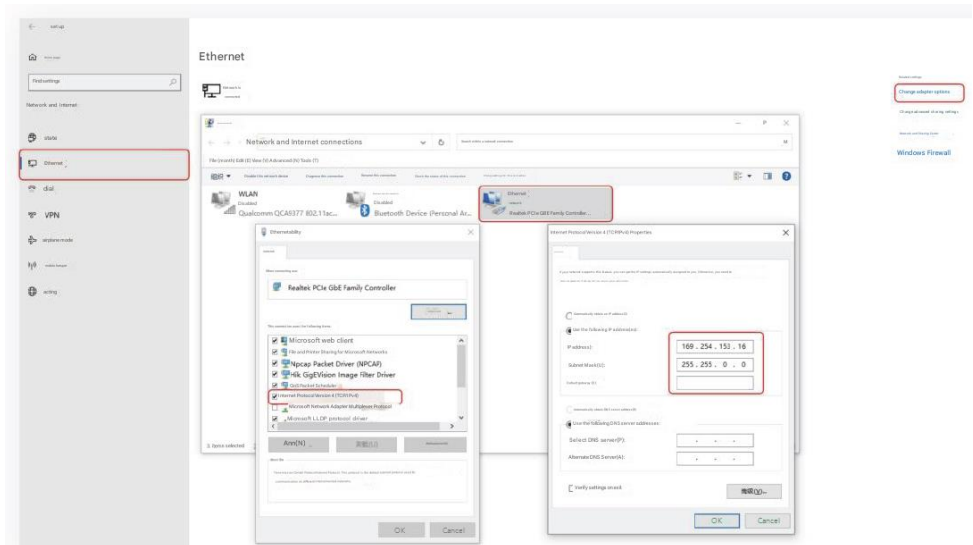

4. Open the configuration software, select the device, and click **Connect**.

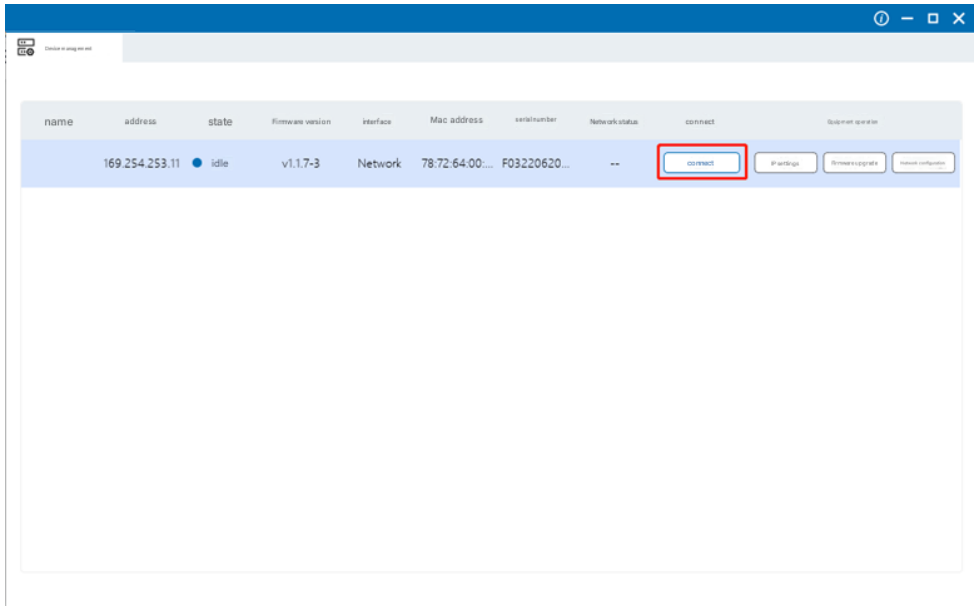

## Changing the Barcode Reader IP Address

1. Open the configuration software and select the corresponding PC network card.
2. When the barcode reader is displayed, click **IP Settings > Use Static**.
3. Choose either **Dynamic IP** or **One-click Match**, then confirm.
4. Adjust the barcode reader IP address to match the same network segment as the PC.

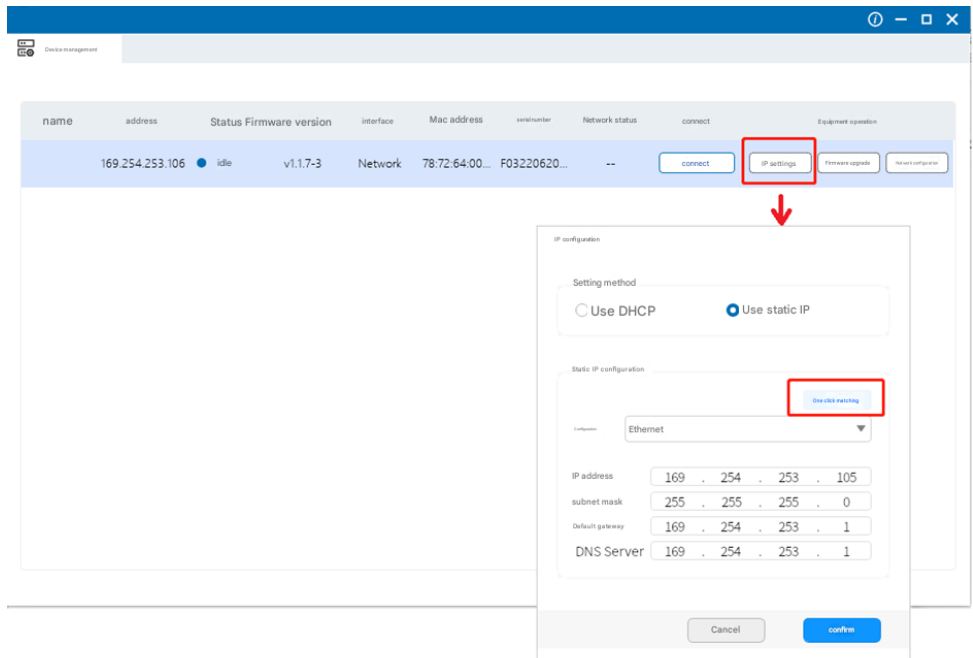

## Firmware Upgrade

1. Navigate to: **Device Management > Device Operation > Firmware Upgrade.**
2. Select the firmware file and click **OK.**
3. Wait for the device to reboot automatically.

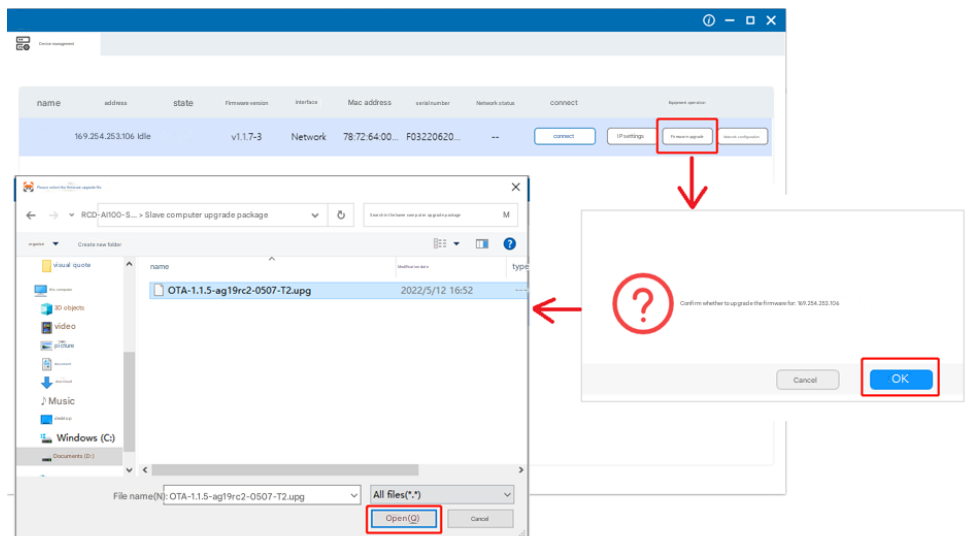

# Function Overview

## Interface Overview

The ZX-1060 can be operated through the client interface.

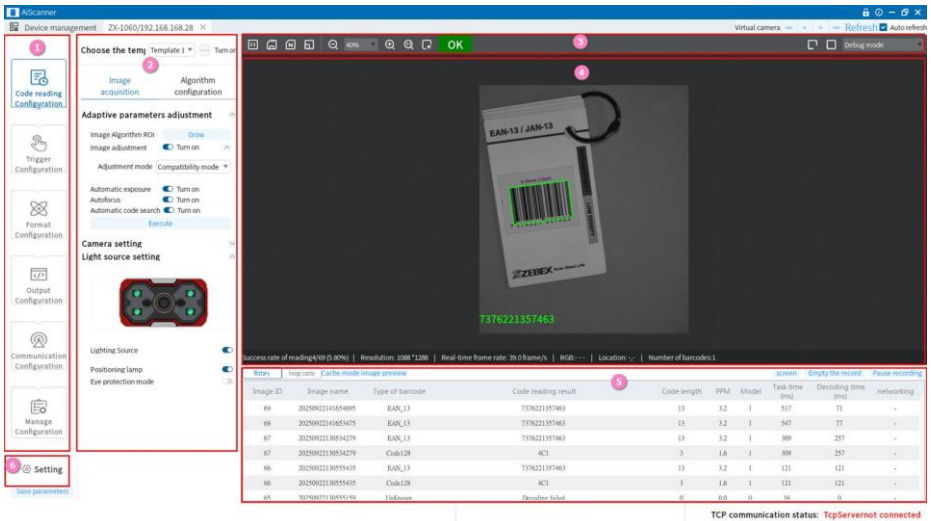

- 1. Menu Bar:** Access basic client functions. Second-level menus allow parameter settings, template selection, and module configuration.
- 2. Barcode Reader Configuration:** Adjust algorithm parameters, start/stop image collection, save/cancel ROI, etc.
- 3. Toolbar:** Quick functions such as zoom, software trigger, and image operations.
- 4. Preview Window:** Displays the live image, real-time decoding results, and ROI drawing effects.
- 5. History Records:** Shows real-time barcode reading results.
- 6. Basic Settings:** Change device name, buzzer settings, button settings, log access, and firmware upgrade.

# Code Reading Configuration

## Template Selection

- Up to **4 templates** are supported (Template 1–4).
- Select from the drop-down menu in **Reader Configuration > Template Selection**.
- Once configured, the template can be saved and reused.

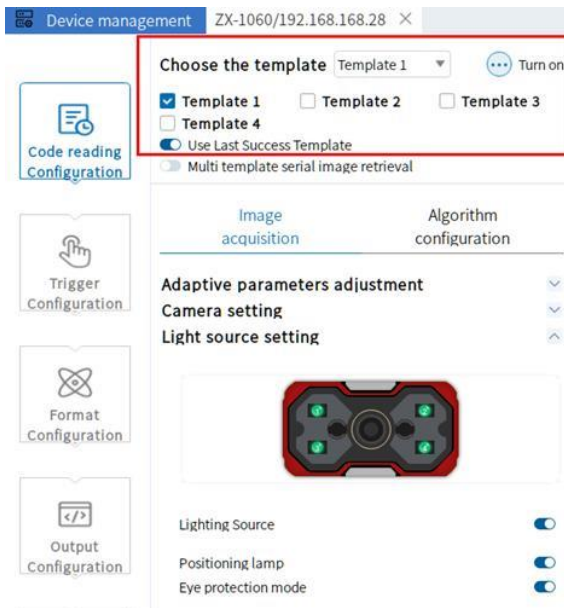

## Image Acquisition

- Adjust **Image Acquisition** parameters if recognition performance is poor: exposure time, gain, focus, light source settings.
- ZX-1060 supports both manual and adaptive automatic adjustment.

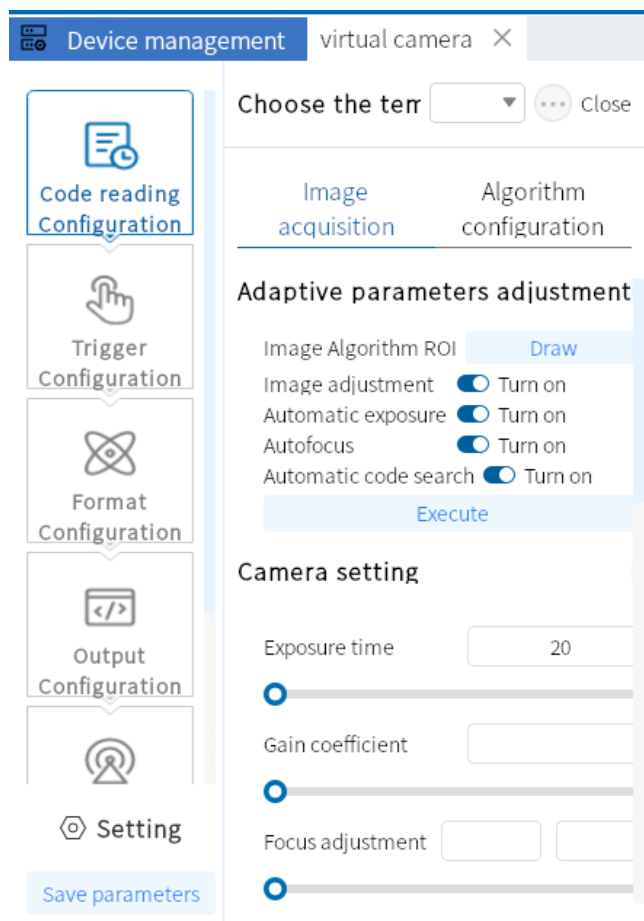

## Adaptive Parameter Adjustment

- Includes ROI optimization, image adjustment, light source adaptation, autofocus, and automatic code search.
- Automatically sets exposure, gain, light, and decoding parameters.

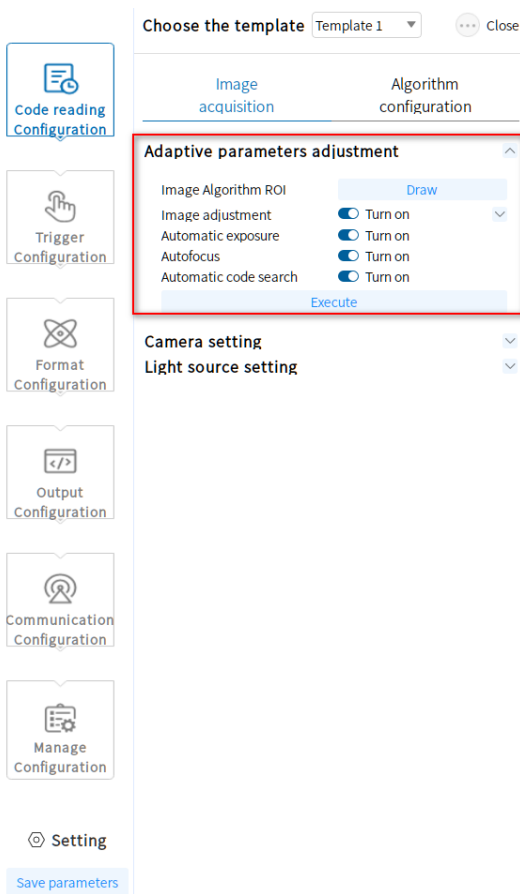

## Camera Settings

- **Exposure Time:** Controls brightness. Longer exposure increases brightness but slows capture speed.
- **Gain Index:** Increases brightness but may introduce noise.
- **Tip:** Balance exposure time and gain for best performance.

The screenshot displays the camera configuration interface. On the left is a vertical sidebar with icons for 'Code reading Configuration', 'Trigger Configuration', 'Format Configuration', 'Output Configuration', 'Communication Configuration', 'Manage Configuration', and 'Setting'. The main panel is titled 'Choose the template' with a dropdown set to 'Template 1' and a 'Close' button. Below this are two tabs: 'Image acquisition' (selected) and 'Algorithm configuration'. Under 'Image acquisition', there are two sections: 'Adaptive parameters adjustment' and 'Light source setting'. The 'Camera setting' section, which is highlighted with a red box, includes the following parameters:

Parameter	Value
Automatic AE	Close (toggle)
Exposure time	564
Gain coefficient	71
Gamma	1.0
Focus adjustment	28

At the bottom of the interface, there is a 'Save parameters' button.

# Light Source Settings

- Controls the ON/OFF status of fill lights.

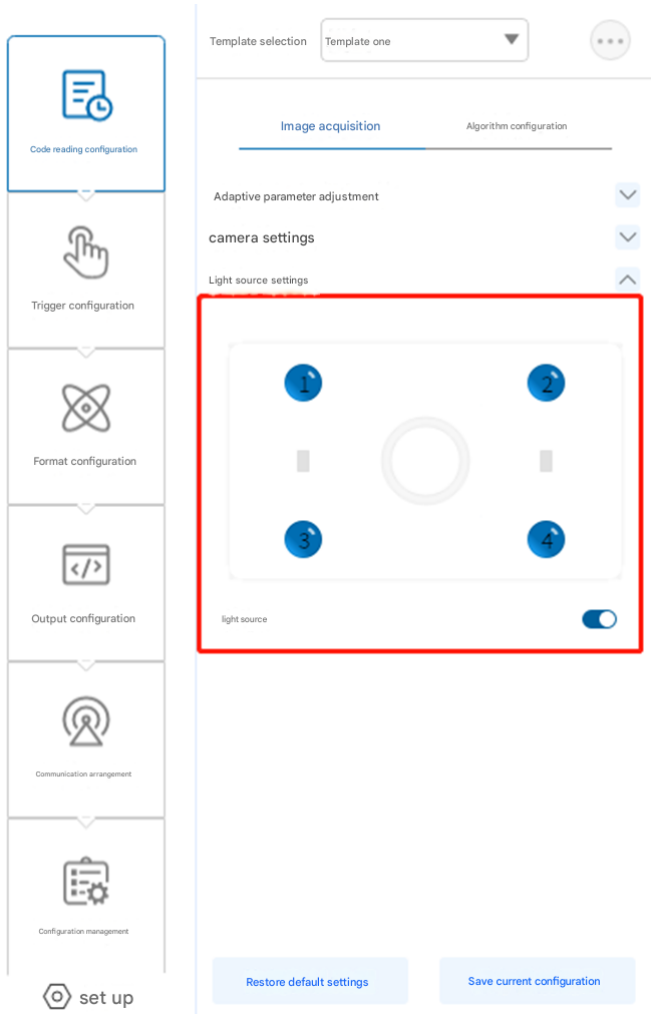

# Algorithm Configuration

## Code Reading Type

- Supports **1D** and **2D** barcode types. Multiple selections allowed.
- The more code systems selected, the longer decoding time; select only as needed.

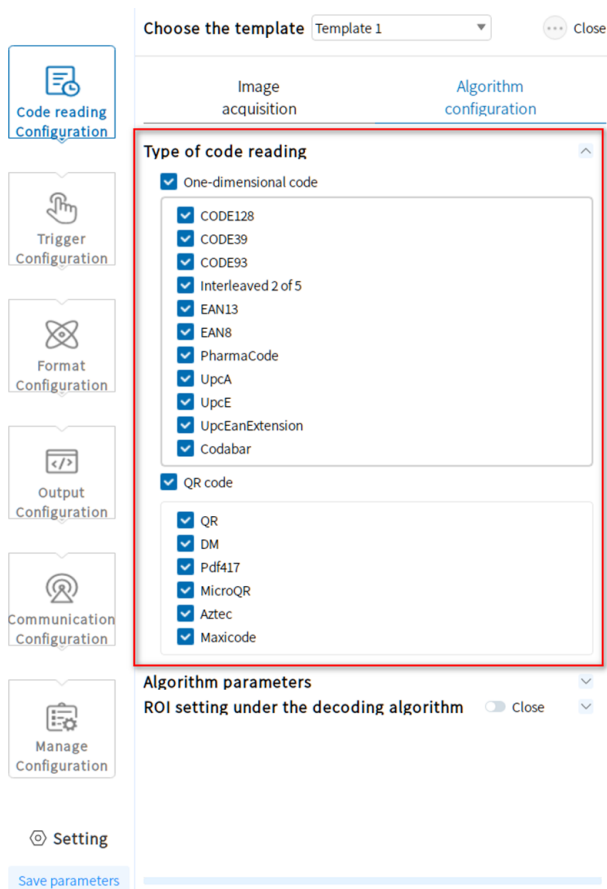

## Algorithm Parameters

- **Polarity:** White background/black code, Black background/white code, Compatible mode
- **Edge Type:** Continuous, Discrete, Compatible
- **Mirror Mode:** Mirror, Non-mirror, Compatible
- **QR Distortion:** Distortion, Non-distortion, Compatible
- **DM Code Type:** Square, Rectangle, Compatible
- **Operation Mode:** Extreme Speed, Normal, Expert
- **Output Limits:** Maximum number of 1D codes and QR codes

Choose the template Template 1

Image acquisition Algorithm configuration

**Algorithm parameters**

- Algorithm time limit: 2000 ms
- Image Preprocess:  Close
- Algorithm type: Normal Mode
- Intelligent rating: Close 4
- GS1: Close
- GS1 interception:  Turn on
- UDI(C128): Close
- DMECC: Auto
- ISO code based rating standards: ISO1541x
- 1D/2D Barcode Configuration: One-dimensional code
- Application Mode: Normal Mode
- Code39 check: Off
- 1D Code Number: 1
- One-dimensional coding system rating: Off
- Code based rating:

## ROI (Region of Interest) Settings

- Define areas for decoding; ignore unnecessary regions.
- Multiple ROIs can be set and prioritized.
- If no code is detected, “noread” is output.

Choose the template Template 1 Close

Image acquisition Algorithm configuration

Type of code reading ▼

Algorithm parameters ▼

**ROI setting under the decoding algorithm**  Turn on ▲

Draw ROI manually Draw

Add multiple ROI in a batch Draw

Clear all ROI Clear

ROI number offset

Code reading Configuration

Trigger Configuration

Format Configuration

Output Configuration

Communication Configuration

Manage Configuration

Setting



# Batch ROI (Checkerboard)

- Define multiple ROIs at once with adjustable spacing, size, and number of rows/columns.

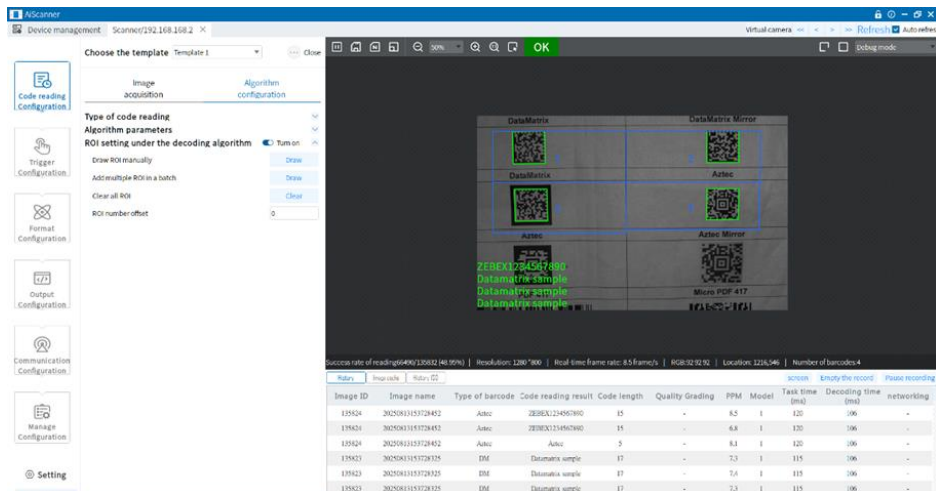

## Clear All ROIs

- Clears all ROI settings.

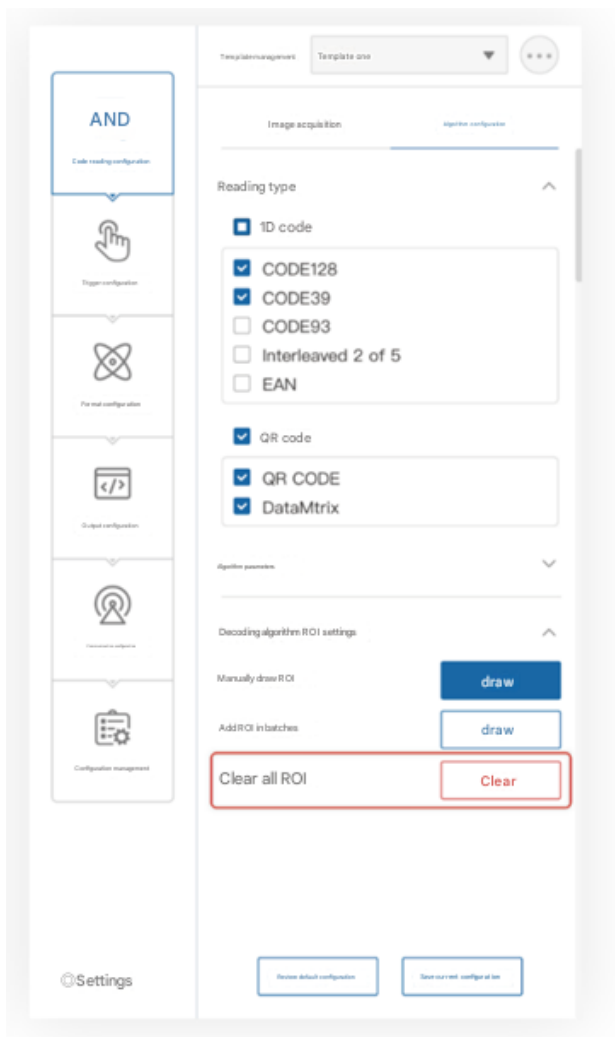

# Trigger Configuration

## Trigger Types

The device supports the following trigger modes: **Continuous Trigger**, **I/O Trigger**, **Software Trigger**, **Network Trigger**, and **Serial Trigger**.

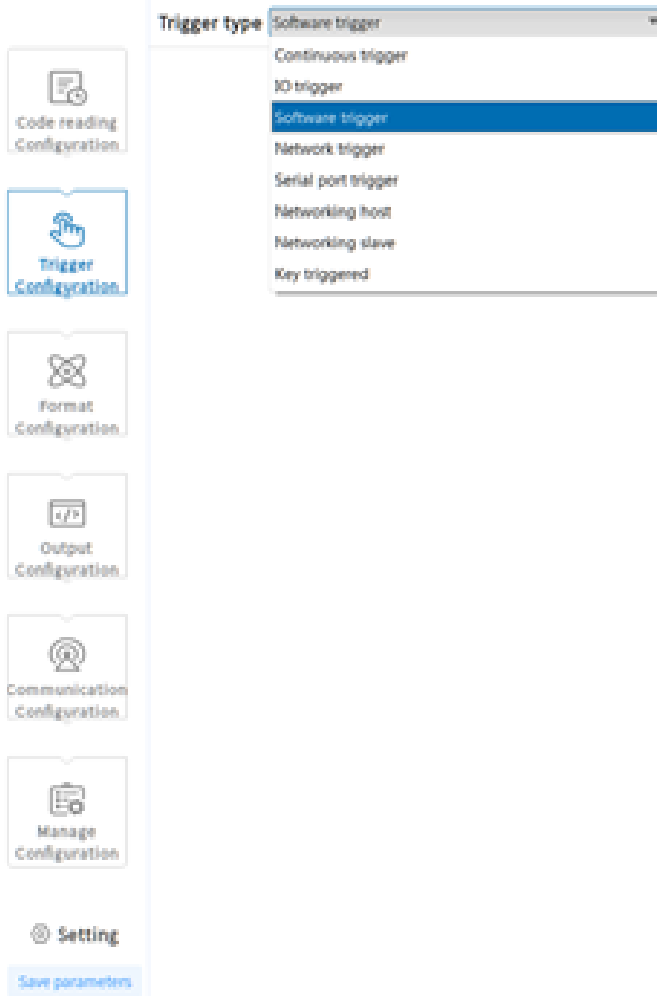

## Continuous Trigger

Continuous trigger means the reader continuously captures and decodes images.

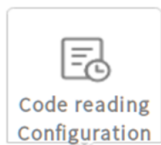

Trigger type

### Continuous trigger

Use default values

Reading success status feedback

ms

## I/O Trigger

I/O trigger means the reader will capture and decode when it receives an external signal.

This mode must be enabled under “Single (External)” mode before it can be configured.

- **Task Timeout:** Sets the maximum task time for a single trigger. If the trigger remains active beyond the timeout value, the task will be forcibly stopped.
  - Default: 9999
  - Range: 10–9999

Trigger type IO trigger

**IO trigger**

Task timeout  Timeout enable  ms

The task time is fixed to a timeout time

Decode all images

Multiple Barcode termination Enable  Codes

Continuous code reading during the mission period

Image collection mode Cache Mode

Maximum number of images

get image frequency 1 out of 1

IO anti shake time  us

IO trigger signal cache one

**Trigger starts**

Delay trigger  ms

Trigger signal Line0

Trigger form Rising edge

**Trigger ends**

Trigger immediate stop

Delay trigger  ms

Trigger signal Line0

Trigger form Falling edge

Code reading Configuration

Trigger Configuration

Format Configuration

Output Configuration

Communication Configuration

Manage Configuration

Setting

Save parameters

## Start Trigger

Enable/disable the configuration page for start trigger.

## End Trigger

Enable/disable the configuration page for end trigger.

- **Trigger Delay:**
  - In Start Trigger: Delay between receiving a trigger signal and starting the reading process.
  - In End Trigger: Delay between receiving an end signal and stopping the reading process.
  - Default: 0 ms
  - Range: 0–9999 ms
- **Trigger Signal:**
  - Start Trigger: Options are Line0 or Line1, corresponding to hardware input IN0 and IN1.
  - End Trigger: Options are Line0 or Line1, corresponding to hardware input IN0 and IN1.
- **Trigger Edge:**
  - Start Trigger:
    - **Rising Edge:** Starts reading when a rising edge signal is received.
    - **Falling Edge:** Starts reading when a falling edge signal is received.
  - End Trigger:
    - **Rising Edge:** Stops reading when a rising edge signal is received.
    - **Falling Edge:** Stops reading when a falling edge signal is received.

## Software Trigger

By clicking **Software Trigger** in the interface, the reader can be activated for image capture and decoding.

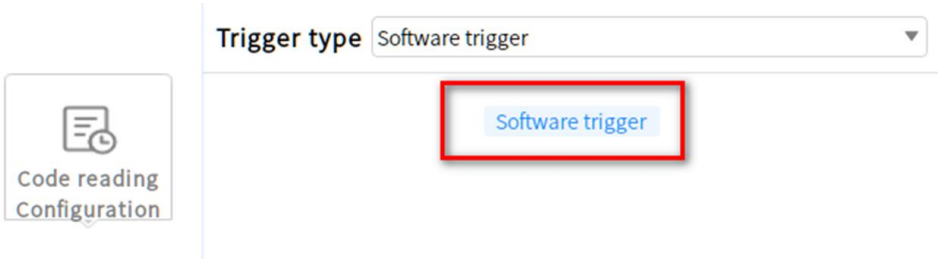

## Network Trigger

Configures the maximum task time for a single trigger. If the trigger remains active beyond the timeout value, the task will be forcibly stopped.

- Timeout range: 10–9999
- Maximum image count: 1–100

# Format Configuration

The format configuration includes **Data Filtering** and **Data Processing**, allowing configuration of filtering rules and output data.

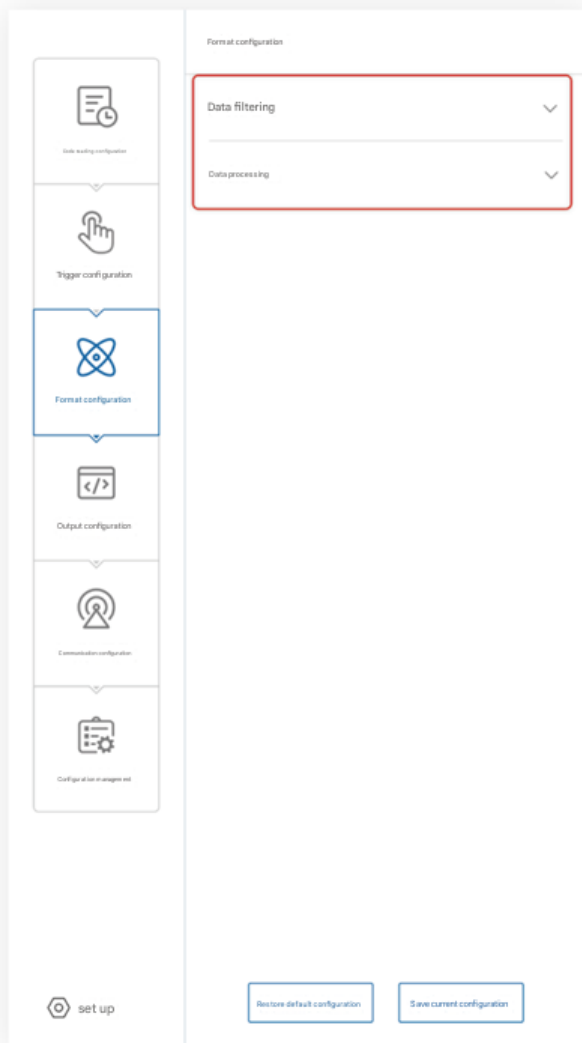

## Data Filtering

Filters barcode results based on predefined rules.

- **Repeat Time Filter:** Prevents repeated codes from being output within a specified time window. (Range: 30–30000 ms)
- **Re-read Count Filter:** Prevents output if the same code is read more than the specified number of times. (Range: 1–100)
- **Barcode Length Restriction:** Outputs only barcodes within the specified length range.
- **Specified Prefix/Suffix:** Outputs only barcodes starting or ending with specified strings. Multiple entries allowed.
- **Must Contain / Must Not Contain:** Outputs barcodes that include or exclude specified strings. Multiple entries allowed.
- **Character Offset:** Outputs barcode data starting from a specific character position.
  - Example: Code = 1232334, Offset = 3 → Output = 2334.
- **Character Type Requirement:** Restrict output to digits only, letters only, or alphanumeric.
- **Barcode Validation:** Input reference string for validation. Display shows OK if conditions are met, NG if not.

## Data Processing

Configures the output processing rules for decoded barcodes. Parameters vary depending on selected communication protocol.

- **Sorting Method:** Supports multiple sorting options:
  1. Barcode length ascending/descending
  2. Barcode type ascending/descending (1D/2D)
  3. ROI number ascending/descending
  4. Barcode center X or Y coordinate ascending/descending
  5. Barcode position ascending/descending (X, Y)
- **Delimiter Options:** Semicolon (;), comma (,), slash (/), backslash (\), underscore (\_), hyphen (-).
- **Data Template:** Used to customize output format.
- **Output Start/End:** Allows inclusion of barcode content, type, angle, coordinates, quality level, ROI ID, PPM, timestamp, and custom strings.
- **ROI No-Read Completion:** If no code is detected in ROI, outputs a failure string.
- **Failure String:** Defines the output when decoding fails.

## Output Configuration

The device provides three output channels, each configurable with an output duration of 0–9999 ms.



Code reading  
Configuration



Trigger  
Configuration



Format  
Configuration



Output  
Configuration



Communication  
Configuration



Manage  
Configuration



Setting

[Save parameters](#)

### Configuration of output

**OUTLINE0** Output reverse  Turn on

Code reading succeeded  Code reading failed  Exception

Heartbeat Timeout

Trigger Character

Output duration:  ms

**OUTLINE1** Output reverse  Turn on

Code reading succeeded  Code reading failed  Exception

Heartbeat Timeout

Trigger Character

Output duration:  ms

**OUTLINE2** Output reverse  Turn on

Code reading succeeded  Code reading failed  Exception

Heartbeat Timeout

Trigger Character

Output duration:  ms

**Trigger character reception timeout**  Turn on

timeout  ms

OUT0  OUT1  OUT2

**IO\_ Out trigger source**  Turn on

Trigger Source Selection

IP address

Subnet mask

TCP port

heartbeat

Heartbeat identifier:

## OUT Settings

Each output corresponds to hardware outputs OUT0, OUT1, OUT2.

- Configurable output states: **OK** (successful decode), **Fail** (decode failed), **Error** (device error/self-check failure).
- **Output Duration:** Default 9 ms, adjustable 0–9999 ms.

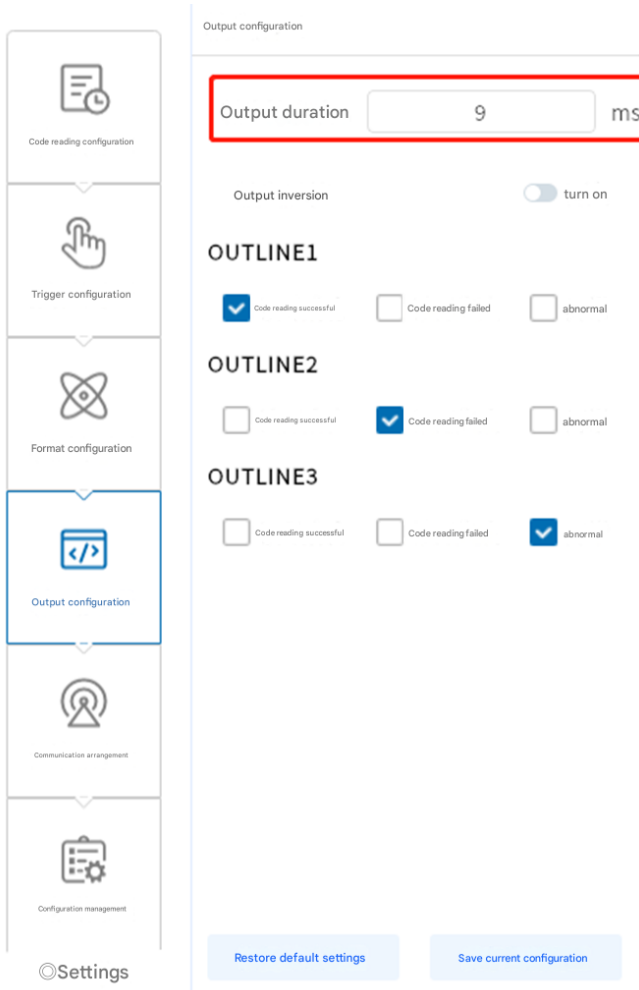

# Communication Configuration

---

Supports **TCP** and **Serial** communication. Protocol selection depends on device operation mode.

## TCP Server

Standard TCP communication where the scanner operates as a server.

Use the TCPServer protocol ^

IP address

Subnet mask

TCP port

TCP Port 2

heartbeat

Heartbeat Timeout:

Heartbeat identifier:

## Modbus TCP

Requires configuration of:

- Server IP address
- Server port
- Device ID
- Data address
- Data length (bytes)
- Trigger address
- Trigger data length

Use the ModbusTCP protocol ^

Server  Client

Byte exchan

State machine mode  Status Register Mode

Modbus service port	<input type="text" value="502"/>
Device station No.	<input type="text" value="1"/>
Transmission address	<input type="text" value="10"/>
Length of transmission data bit	<input type="text" value="10"/>
Trigger address	<input type="text" value="0"/>
Length of trigger data bit	<input type="text" value="10"/>

## MC Protocol

Requires configuration of:

- Server IP address
- Server port
- Device ID
- Network ID
- Data address
- Data length (bytes)

Use the MC protocol ^

Tcp  Udp

Status Register Mode

MC service IP

MC service port

Device station No.

Device network No.

Transmission address

Length of transmission data bit

trigger addr type

Trigger address

Length of trigger data bit

## Serial Protocol

When Serial is selected, parameters include:

- Baud rate
- Parity
- Data bits
- Stop bits

**Configuration of communication** Serial port ▾

---

**Serial port** ⤴

search COM

Baud rate 9600 ▾

Parity check None ▾

Data bit 8 ▾

Stop bit 1 ▾

Delayed output

Number of characters sent per time

Character spacing (0-1000ms) {0-2000m?}

Task interval (0-1000ms) {0-2000m?}

## Modbus RTU

Requires configuration of:

- Device ID
- Data address
- Data length (bytes)
- Trigger address
- Trigger data length

Use the ModBusRTU protocol

Server     Client

Byte exchange

Device station No.

Transmission address

Length of transmission data bit

Trigger address

Length of trigger data bit

# Device Management

Options include:

- **Restore Factory Defaults**
- **Save All Configurations**

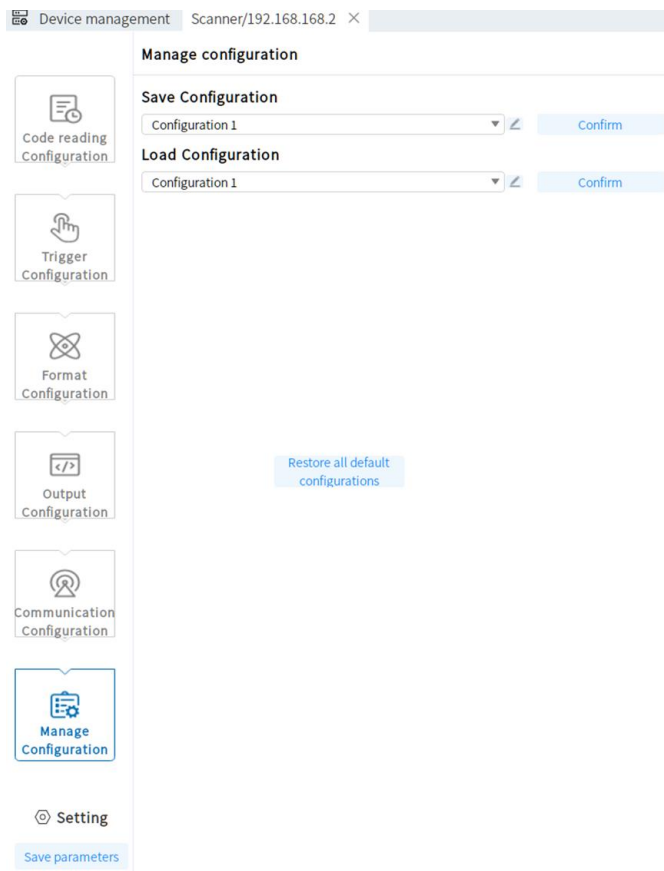

# Settings

## Device Settings

- **Device Name:** Modify the scanner device name. Supports Chinese, English, alphanumeric, and symbols.
- **Buzzer:** Enable buzzer sound on success/failure. Configurable durations: 40 ms / 80 ms / 120 ms.
- **Keys:** Enable/disable trigger button, function button, and locator light.

The screenshot shows a 'set up' dialog box with a sidebar on the left and a main content area on the right. The sidebar contains four menu items: 'Device settings' (highlighted), 'Backup and restore', 'Log view', and 'Storage configuration'. The main content area is titled 'set up' and contains the following settings:

- Device settings:** Device name: AiScanner
- Buzzer settings:** Decode sound: Decoding opened successfully (dropdown menu)
- Buzzer settings:** Sound duration: Medium (80ms) (dropdown menu)
- Button settings:** trigger button: Open (dropdown menu)
- Button settings:** Function keys: Open (dropdown menu)
- Positioning light:** Open (dropdown menu)

At the bottom right of the dialog box, there are two buttons: 'Restore default settings' and 'Save current settings'.

## Firmware Update

Select the firmware file and click Upgrade to complete firmware update.

## Backup & Restore

Back up device settings to PC, restore settings, or reset to factory defaults.

## Log

Supports viewing logs with levels: ERROR, WARN, INFO, DEBUG. Options include Refresh, Clear, and Export.

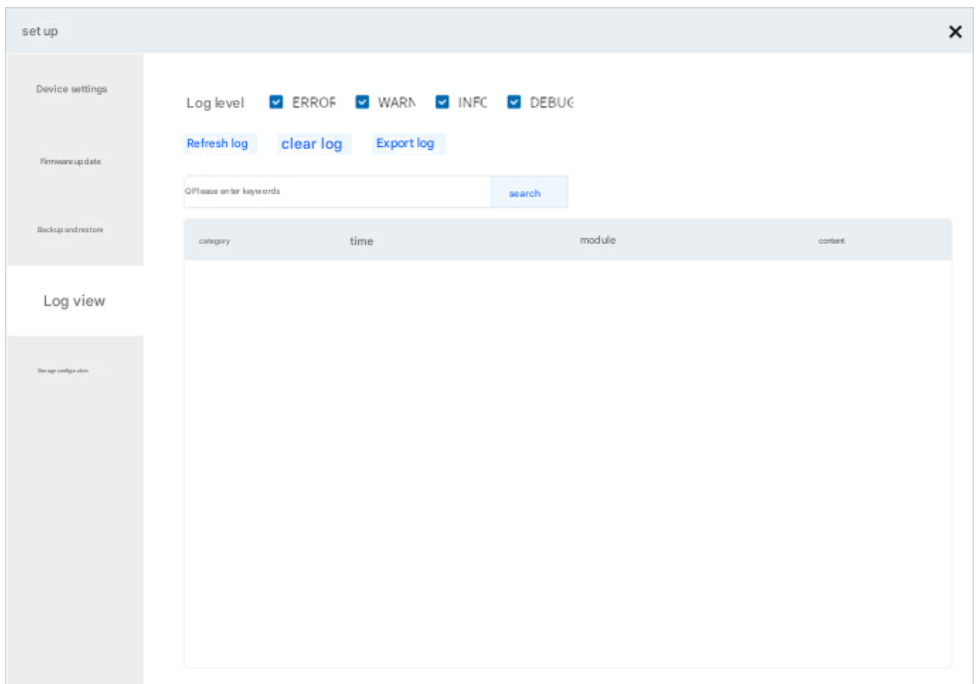

The screenshot shows a web interface titled "setup" with a sidebar on the left containing menu items: "Device settings", "Firmware update", "Backup and restore", "Log view", and "See user configurations". The "Log view" section is active, displaying the following controls and table:

Log level:  ERROR  WARN  INFO  DEBUG

Buttons: Refresh log, clear log, Export log

Search input: Q>Please enter keywords [search]

category	time	module	content
----------	------	--------	---------

## Storage Settings

- **Device Storage:** Enable/disable data logging, decoded images, undecoded images, and raw images.
- **PC Storage:** Select custom save path.
- **Capture Settings:**
  - Save path
  - Capture interval: 1 s–60 min
  - Capture count: 2–10000 images

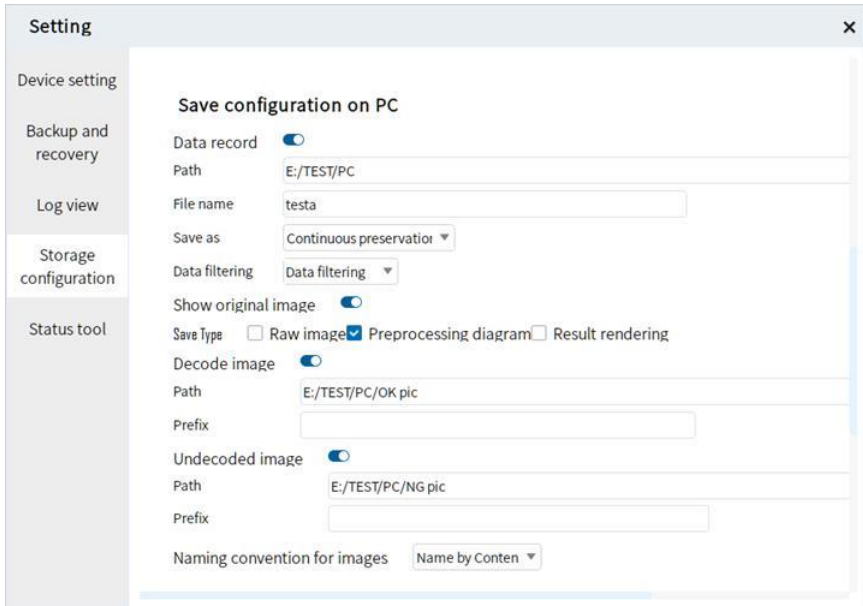

# Frequently Asked Questions

## Device Recognized but “Unreachable”

- Cause: Device IP and PC are in different segments, or PC has multiple IPs.
- Solution: Adjust IP to match network segment. Reset Winsock:

netsh winsock reset

Then restart PC.

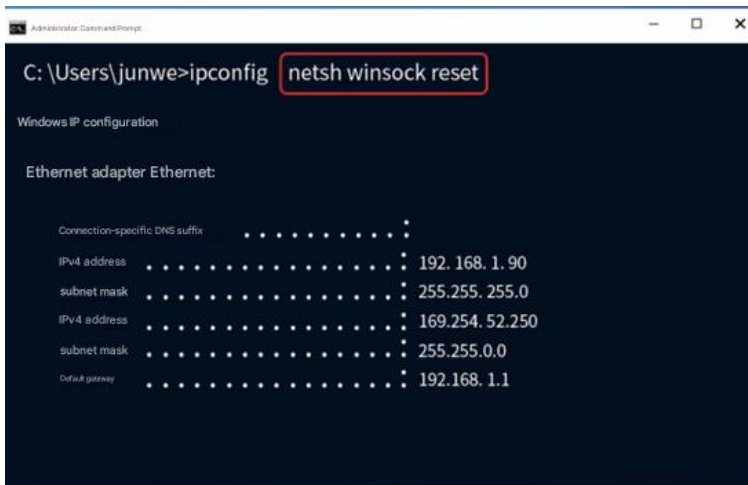

The screenshot shows a Windows Command Prompt window with the following content:

```
C: \Users\junwe>ipconfig netsh winsock reset
```

Windows IP configuration

Ethernet adapter Ethernet:

Connection-specific DNS suffix	.....	.
IPv4 address	.....	192.168.1.90
subnet mask	.....	255.255.255.0
IPv4 address	.....	169.254.52.250
subnet mask	.....	255.255.0.0
Default gateway	.....	192.168.1.1

## Debug Mode Settings Not Saved

- Cause: Temporary storage requires manual saving.
- Solution: **Configuration Management > Save All Configurations.**

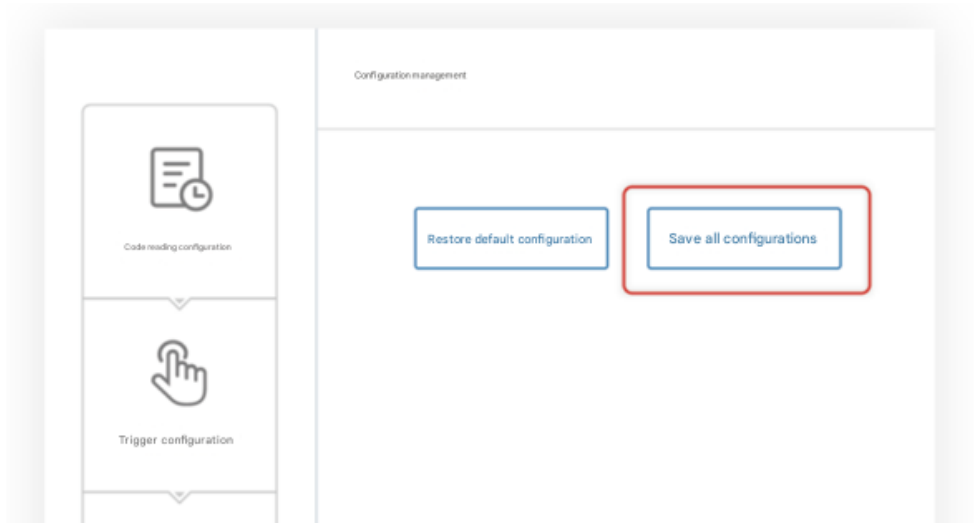

## Barcode on Metal/PCB Cannot Be Read

- Causes: Low brightness, high reflectivity.
- Solution: Increase **Light Source** or **Gain**, adjust angle and exposure.

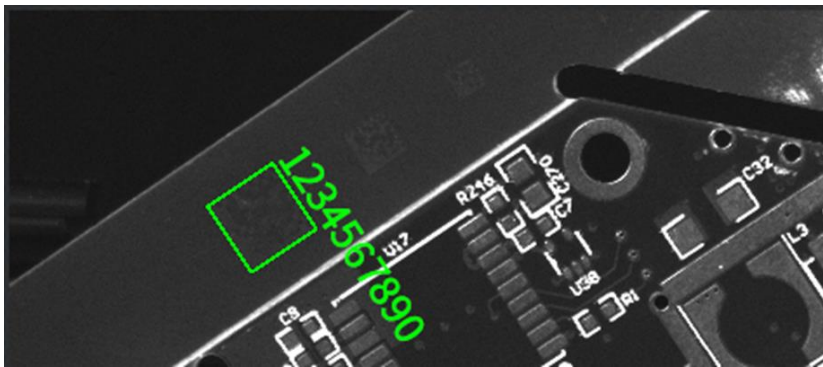

## Small Barcode Cannot Be Recognized

- Cause: Insufficient resolution (PPM too low). 1D codes require **PPM  $\geq$  2**, QR codes require **PPM  $\geq$  3**
- Solution: Move the reader closer.

## Using Different Trigger Modes

- Network Trigger: Same port/IP, verify with third-party software
- IO Trigger: Connect lines, configure NPN/PNP
- Serial Port Trigger: Configure DB9, baud rate, data bits, stop bits
- Software Trigger: Ensure same network segment

## Network Trigger Failure

- Cause: Device only supports client mode.
- Solution: Adjust PLC device network trigger mode.